

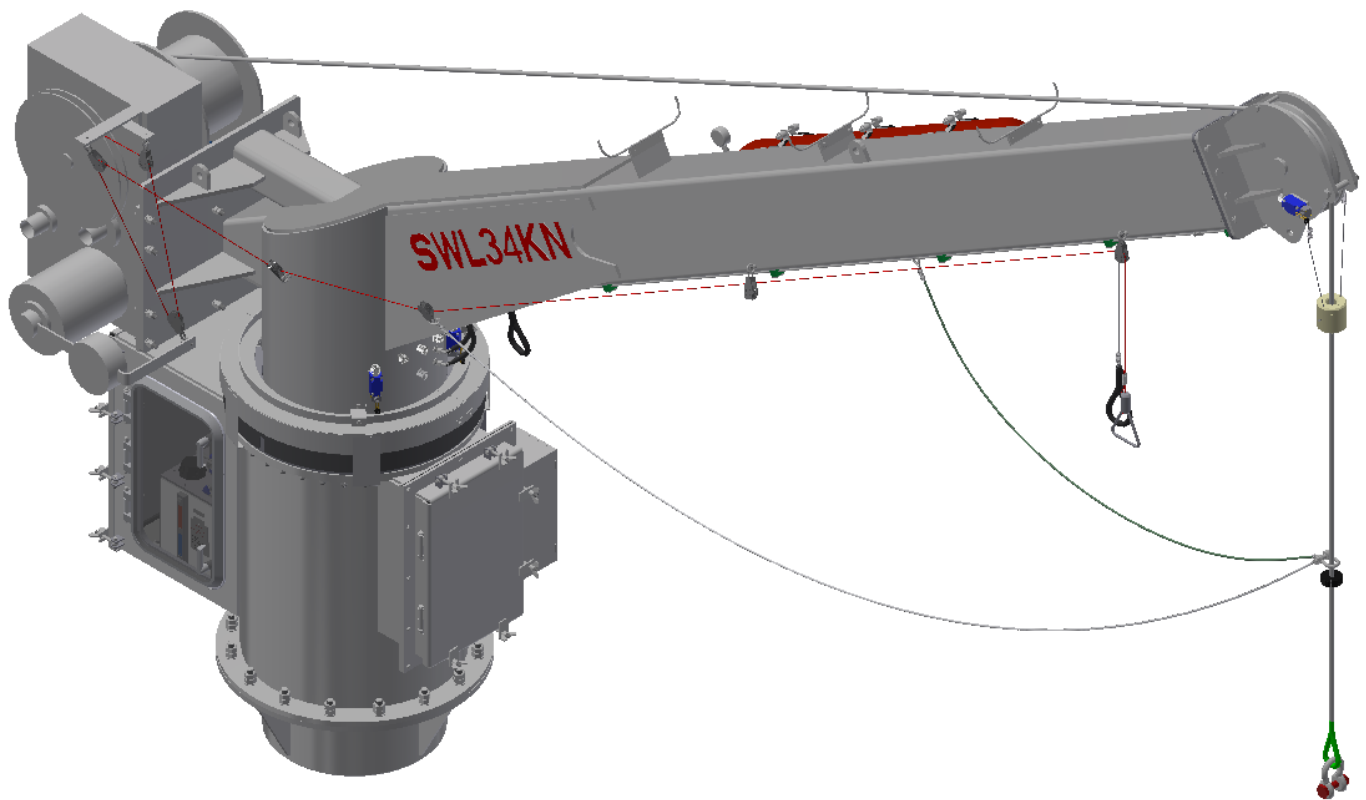

**VIKING
NORSAFE**
Boats and davits

Enterprise No.: NO940411696
www.VIKING-life.com

NDSC-34 – Rescue Boat Davit



TECHNICAL SPECIFICATION

VIKING Norsafe Life-Saving Equipment Norway AS
Tybakken 90, N-4818 Faervik
P.O. Box 115, N-4852 Faervik
Arendal, Norway

VIKING Project No.: Standard

VIKING Doc. No.: TSD-0048

Rev. Date: 08.03.2022

Rev. No: 7

Tel: +47 37 05 85 00

Fax: +47 37 05 85 01

E-mail: VIKING-Norsafe@VIKING-life.com

1. REGULATION AND CERTIFICATION

Applicable rules and regulations In accordance with IMO/ SOLAS requirements, LSA Code and European Council Directive 2014/90/EU on Marine Equipment (MED)

Certificate	MED
Other certificate	Class certificate or flag acceptance on request

2. DAVIT SPECIFICATION

2.1. GENERAL DAVIT

Type	Rescue Boat Davit
Model	NDSC-34
Application	Rescue boat & Life raft handling
Drawing reference	G-500207, G-500208, G-500363, G-500755
Execution	Hydraulic slewing arm davit
Boarding position	Inboard / Outboard on deck level
Operating position	From deck side and from inside the boat (Gravity lowering)
Davit system weight (Approx.)	2800 kg, davit incl. winch (dry weight)
Safe Working Load (SWL)	34 kN (max. 4.5 m slewing radius)
Trim / list conditions	10° / 20°
Max. lowering height	40 m (including 10°/20° trim/list condition)
Operation temperature	-20°C till +45°C (other range on request)
Min. hoisting speed	Hydraulically 18 m/min
Lowering speed	Not less than that obtained from the formula $S=0.4+(0.02H)$, and not exceed 1.3 m/s.
Manual hoisting	By manual hand-cranking
Pivot bearing type	Slewing bearing
Wire sheaves	Galvanized, equipped with ball bearings
Installation	1 (one) deck welding point (reduced installation time)
Deck reinforcement requirements	See general arrangement drawing
Davit system H / W / D	See general arrangement drawing
Deck space required	See general arrangement drawing

The VIKING Norsafe NDSC slewing davit system is especially designed for safe and efficient launching and retrieval of VIKING Norsafe Rescue Boats and life rafts. The davit system is designed for long time operation in a tough and corrosive marine/offshore environment and to fulfil all requirements as given in latest SOLAS/IMO requirements.

The system will allow:

- Hoisting and lowering of the fully loaded rescue boat up to 20° list and 10° trim.
- Gravity lowering of the fully loaded boat up to 20° list and 10° trim, completely independent of any power supply.
- Hoisting of the loaded rescue boat by electric motor.



VIKING
NORSAFE

VIKING Project No.: Standard

VIKING Doc. No.: TSD-0048

Rev. Date: 08.03.2022

Rev. No: 7

- Dead ship slewing of the rescue boat by the nitrogen accumulator installed on the davit arm.
- Retrieval of the rescue boat by manual hoisting.
- Manual slewing by hand pump.

The davit system has a hydraulically driven, mechanical slewing jib and an electric driven winch with single wire fall. Slewing and dead ship slewing functions are driven by a small hydraulic power pack. The hydraulic system is equipped with a stored power unit - which allows full operation of the davit in “dead ship” conditions.

The davit is designed to achieve optimum performance in terms of safety and reliability, and minimal maintenance levels. All selected equipment is chosen and installed to ensure the lowest possible emission of sound and for good access for service and repair.

A HPU is included, and is located inside of the davit pedestal. All internal hydraulic piping is properly done and completed on the entire davit system. A remote control for start/stop of el motor on HPU as well as hoisting and slewing control is also included. When the button is released, davit operation will cease immediately. A thermal overload relay in the starter cabinet protects the electrical motor against overheating in case of excessive loads.

A safety valve is installed in the hydraulic power unit. This safety valve prevents the davit from slewing loads in excess of the Safe Working Load and protects the system and motor from being overloaded.

The winch is fitted with a one-way clutch. In the event of power loss during hoisting, the brake will automatically activate and davit motion will stop. A centrifugal brake is located on the winch. The brake controls the speed of descent for the lifeboat. The brake is enclosed, and provides reliable operation in all climate conditions.

Electrical limit switches are used to cut power to the winch, if the boat is hoisted above stowage height.

Electrical limit switches will prevent the boat from being hoisted above its upmost position / stowed position. Electrical limit switches on the winch provide failsafe operation of the hand crank.

For launching in dead ship conditions, stored power from accumulator and gravity lowering system in winch provides safe launching.

Starter cabinet is mounted on HPU as standard. All electrical cables for davit control, included 42V AC to rescue boat when that is needed is installed and terminated by VIKING Norsafe. Only main power supply is required.

2.2 WINCH AND WIRE

Type	DW-34 winch
Drawing reference	DS-01025
Execution	Electrical hoisting and lowering / Gravity lowering / Manually hoisting / Manually fast hoisting
Brakes type	Centrifugal brakes
Wire rope type	Galvanized, rotation resistant (certified item)



VIKING Project No.: Standard

VIKING Doc. No.: TSD-0048

Rev. Date: 08.03.2022

Rev. No: 7

Wire rope diameter, MBL and spec.	Ø 18 mm, MBL 204 kN, 1960N/mm ²
Inner / outer wire end	Secured to drum / Swaged eye
Connection shackle in thimble	Included (certified item)

2.3. ELECTRICAL

Electric power supply	440V/3ph/60Hz (other on request)
Electrical cabinet	IP56
Remote control	IP56
Limit switch	IP56
Power consumption	11.6 kW (HPU); 18.0 kW (Winch)
Starting method	DOL - Direct on line
Duty rating	S2-10 min
Motor space heating	Included, 40W
Wiring	Included, (only power supply cable required)
Cables type	Marine type, flame retardant halogen free
Transformer	Included, 440/42VAC (other on request)
Emergency stop	Yes, mushroom type

2.4. HYDRAULIC

Type	Independent integrated hydraulic system
Oil flow	22.7 l/min (at 50Hz); 27.4 l/min (at 60Hz)
Max. working pressure	230 bar
Oil amount	47 l
Motor type	132M-4
Hydraulic accumulators	1x Bladder type 50L (120 degree slewing angle)
System fittings	ISO 8434-1 (DIN 2353) bite type fittings
Fittings and hose fittings	Zinc chromate Cr(VI)-free, secured with Denso tape
Tubes	AISI 316L

2.5. PAINTING SYSTEM

Blasting	SA 2.5
Specification	ISO 12944-5
System	Marine paint system (Jotun paint system)
Coating Two (2) layers (other on request)	Layer 1 Penguard universal, Alu - 190 µm Hardtop XP - 50 µm RAL 9016 (Traffic white)
Total dry film thickness	240 µm

2.6. DOCUMENTATION

Technical specification davit	According to contract specification
General arrangement drawing	According to contract specification
Hydraulic flow diagram	According to contract specification



HPU drawing	According to contract specification
Electrical wiring diagram	According to contract specification
Starter cabinet drawing	According to contract specification
Product certificate	According to contract specification
Lubrication oil chart	VIKING Norsafe standard
Spareparts list	VIKING Norsafe standard
Operation & Maintenance manual	VIKING Norsafe standard
Installation manual	VIKING Norsafe standard
Preservation & storage procedure	VIKING Norsafe standard

3. PACKING

Format **Packed for transport in a 40 ft standard container**

4. OPTIONS

Note: Some options influence davit weight and performance, some option combinations may be incompatible. Maximum SWL must not be exceeded.

marking means to be supplied by maker, marking means not supplied by maker.

GENERAL DAVIT	
Combined rescue / raft davit function (maximum handling of rescue boat and 2 rafts)	<input type="checkbox"/>
Rescue boat release hook	<input type="checkbox"/>
Automatic release raft hook (including triangle plate)	<input type="checkbox"/>
Combined raft-/rescue hook	<input type="checkbox"/>
Winterization / cold climate heating / canvas solutions	<input type="checkbox"/>
Commissioning performed by VIKING Norsafe or VIKING Norsafe Service Partners	<input type="checkbox"/>
Other options on request	<input type="checkbox"/>
ELECTRIC SYSTEM	
Voltage variation	<input type="checkbox"/>
Protection box for remote control	<input type="checkbox"/>
Ex-proof, Zone II 2 G Ex de IIB T3 (other on request)	<input type="checkbox"/>
Star Δ starting method	<input type="checkbox"/>
Additional electric cabinet heater	<input type="checkbox"/>
Alternative cabinet size / material / surface protection	<input type="checkbox"/>
HYDRAULIC SYSTEM	
Stainless steel fittings and hose fittings	<input type="checkbox"/>
Stainless steel HPU tank	<input type="checkbox"/>
Alternative HPU size / material / surface protection	<input type="checkbox"/>
HPU heater	<input type="checkbox"/>



VIKING Project No.: Standard

VIKING Doc. No.: TSD-0048

Rev. Date: 08.03.2022

Rev. No: 7

Increased accumulator capacity (increased stored power slewing angle, up to max.300 degree)	<input type="checkbox"/>
---	--------------------------

PAINTING SPECIFICATION

Norsok M-501 system (VIKING Norsafe Doc. No. TSS-0030)	<input type="checkbox"/>
Other painting system and final color	<input type="checkbox"/>

SPARE PARTS

Spare parts for Startup / Commissioning	<input type="checkbox"/>
Spare parts for Onboard spare	<input type="checkbox"/>
Spare parts for 1 year	<input type="checkbox"/>
Spare parts for 2 years	<input type="checkbox"/>

DOCUMENTATION

Factory acceptance test procedure	<input type="checkbox"/>
Factory acceptance test report	<input type="checkbox"/>
Inspection and test plan	<input type="checkbox"/>
Shipping, handling and lifting procedure	<input type="checkbox"/>
Packing & unpacking procedure	<input type="checkbox"/>
Commissioning procedure	<input type="checkbox"/>
TAG list	<input type="checkbox"/>
Winch drawing	<input type="checkbox"/>
Noise test report	<input type="checkbox"/>
Weight and COG datasheet	<input type="checkbox"/>
Weighing report/certificate	<input type="checkbox"/>
Other drawings/documentation/procedures	<input type="checkbox"/>

5. POSSIBLE BOAT FITTING THIS DAVIT SYSTEM

The VIKING Norsafe boats and liferafts fit the NDSC-34 davit types and variants.

VIKING Norsafe boats

Matrix-450 MKI	Midget-500 MKII
Midget-530 MKII	Merlin-615 MKI
Mako-655 MKI	(Others on request)

VIKING liferafts

25 DKF+	25 DKFS
35 DKF+	(Others on request)



6. YARD SUPPLY / RESPONSIBILITY

Transport	Depending on contract
Deck foundations / reinforcement	
Assembly, erection and welding to deck	
Wire routing on davit and termination	
All cables to starter cabinet and agreed interface	
Hydraulic oil filling	
Testing according to regulation after installation onboard	
Preservation and maintenance after davit arrived yard and installed	



VIKING
NORSAFE