

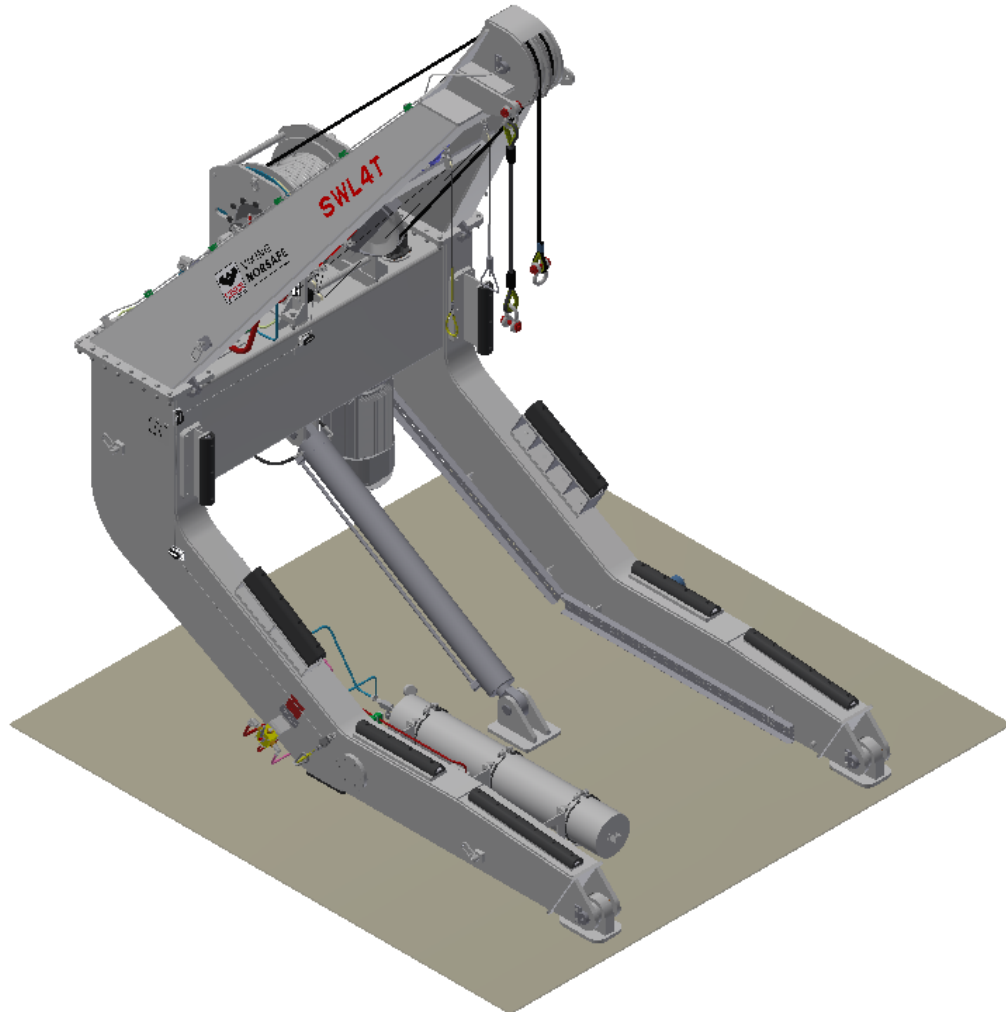

**VIKING
NORSAFE**
Boats and davits

Enterprise No.: NO940411696
www.VIKING-life.com

NRB-40 MKII - Rescue boat davit



TECHNICAL SPECIFICATION

VIKING Norsafe Life-Saving Equipment Norway AS
Tybakken 90, N-4818 Faervik
P.O. Box 115, N-4852 Faervik
Arendal, Norway

VIKING Project No.: Standard

VIKING Doc. No.: TSD-0476

Rev. Date: 14.04.2020

Rev. No: 2

Tel: +47 37 05 85 00

Fax: +47 37 05 85 01

E-mail: VIKING-Norsafe@VIKING-life.com

1. REGULATION AND CERTIFICATION

Applicable rules and regulations In accordance with IMO/ SOLAS requirements, LSA Code and European Council Directive 2014/90/EU on Marine Equipment (MED)

Certificate	MED
Other certificate	Class certificate or flag acceptance on request

2. DAVIT SPECIFICATION

2.1. GENERAL DAVIT

Type	Rescue Boat Davit
Model	NRB-40 MKII
Application	Rescue boat handling
Drawing reference	G-502867
Execution	Hydraulic pivoting davit
Boarding position	Inboard / Outboard on deck level
Operating position	From deck side and from inside the boat (Gravity lowering)
Davit system weight (Approx.)	4000 kg, davit incl. winch (dry weight)
Safe Working Load (SWL)	4000 kg
Trim / list conditions	10° / 20°
Max. lowering height	43 m (including 10°/20° trim/list condition)
Operation temperature	-20°C till +45°C (other range on request)
Min. hoisting speed	Hydraulically 18 m/min
Min. lowering speed	According to SOLAS regulation ($S = 0.4 + 0.02H$)
Manual hoisting	By manual hand-pumping
Pivot bearing type	Bronze bearings
Wire sheaves	Galvanized, equipped with ball bearings
Installation	3 (three) deck welding points (reduced installation time)
Deck reinforcement requirements	See general arrangement drawing
Davit system H / W / D	See general arrangement drawing
Deck space required	See general arrangement drawing

The Viking Norsafe NRB luffing davit system is especially designed for safe and efficient launching and retrieval of Viking Norsafe Rescue Boats. The davit system is designed for long time operation in a tough and corrosive marine/offshore environment and to fulfil all requirements as given in latest SOLAS/IMO requirements.

The system will allow:

- Hoisting and lowering of the fully loaded rescue boat up to 20° list and 10° trim.
- Gravity lowering of the fully loaded boat up to 20° list and 10° trim, completely independent of any power supply.
- Retrieve the rescue boat and store it safely in parking position by manual hand pump operation.



The davit system consists of a steel frame with integrated hydraulic power pack, a hydraulic jib cylinder to handle frame movements and a winch for lowering / hoisting operation. The davit is controlled either by an operator on deck (using deck mounted controls) or by the rescue boat crew from within the boat (by pulling remote control wires). The davit is also operational under “dead ship” condition, where no electric power is provided for the equipment. In this case, a hydraulic accumulator is used to jib out the frame. Descent of the rescue boat is controlled by the hydraulic system (gravity lowering).

The davit is designed to achieve optimum performance in terms of safety and reliability, and minimal maintenance levels. All selected equipment is chosen and installed to ensure the lowest possible emission of sound and for good access for service and repair.

The davit system is fitted with following safety systems:

- To activate the davit, push and hold down the appropriate button to cause the desired operation. When the button is released, davit operation will cease immediately.
- The winch is fitted with hydraulically operated, fail-safe multi-disc brake, which is fully oil submerged. In the event of hydraulic pressure loss, due to hose or connection failure, the brake will automatically activate, and davit motion will stop.
- A safety valve is installed in the hydraulic power unit. This safety valve prevents the davit from lifting loads in excess of the Safe Working Load and protects the system and motor from being overloaded.
- The thermal overload relay in the starter cabinet protects the electrical motor against overheating in case of excessive loads.
- Electro-mechanical limit switch is fitted in the system in order to stop the hoisting motion when the rescue boat reaches upmost position.

2.2 WINCH AND WIRE

Type	NWR-40 S
Drawing reference	G-501708 : NWR-40 S General Arrangement
Execution	Hydraulical hoisting and lowering / Gravity lowering / Manual hoisting
Brakes type	Negative multi-disc brakes, hydraulically operated
Wire rope type	Galvanized, rotation resistant (certified item)
Wire rope diameter, MBL and spec.	Ø 18 mm, MBL 236 kN, 1960N/mm ²
Inner / outer wire end	Secured to drum / Swaged eye
Connection shackle in thimble	Included

2.3. ELECTRICAL

Electric power supply	440V/3ph/60Hz (other on request)
Electrical cabinet	IP56
Remote control	IP56



Limit switch	IP66
Power consumption	26.4 kW
Starting method	DOL - Direct on line
Duty rating	S6-40%
Motor space heating	Included, 40W
Wiring	Included, (only power supply cable required)
Wiring	Included, (only power supply cable required)
Transformer	Included, 440/42VAC (other on request)
Emergency stop	Yes, mushroom type

2.4. HYDRAULIC

Type	Independent integrated hydraulic system
Oil flow	61 l/min @60HZ
Max. working pressure	280 bar
Oil amount	375 l
Motor type	180L-4
Hydraulic accumulators	1xBladder type 10L & Piston type 40L
Hydraulic cylinders	DS-02456 (Main cylinder), DS-00417 (Damping cylinder)
System fittings	ISO 8434-1 (DIN 2353) bite type metric fittings
Fittings and hose fittings	Zinc chromate Cr(VI)-free, secured with Denso tape
Tubes	AISI 316L

2.5. PAINTING SYSTEM

Blasting	SA 2.5
Specification	ISO 12944-5
System	Marine paint system (Jotun paint system)
Coating Two (2) layers (other on request)	Layer 1 Penguard universal, Alu - 220 µm Hardtop XP - 80 µm RAL 9016 (Traffic white)
Total dry film thickness	300 µm

2.6. DOCUMENTATION

Technical specification davit	According to contract specification
General arrangement drawing	According to contract specification
Electrical wiring diagram	According to contract specification
Starter cabinet drawing	According to contract specification
Product certificate	According to contract specification
Lubrication oil chart	Viking Norsafe standard
Spareparts list	Viking Norsafe standard
Operation & Maintenance manual	Viking Norsafe standard
Installation manual	Viking Norsafe standard
Preservation & storage procedure	Viking Norsafe standard



VIKING Project No.: Standard

VIKING Doc. No.: TSD-0476

Rev. Date: 14.04.2020

Rev. No: 2

3. PACKING

Format

Packed for transport in a 20 ft standard container

4. OPTIONS

Note: Some options influence davit weight and performance, some option combinations may be incompatible. Maximum SWL must not be exceeded.

marking means to be supplied by maker, marking means not supplied by maker.

GENERAL DAVIT	
Support cradle for boat in stowed position	<input type="checkbox"/>
Embarkation platform/ladder for boat in stowed position	<input type="checkbox"/>
Anti-pendulum boat supports	<input type="checkbox"/>
Commissioning performed by Viking Norsafe or Viking Norsafe Service Partners	<input type="checkbox"/>
Other options on request	<input type="checkbox"/>
ELECTRIC SYSTEM	
Voltage variation	<input type="checkbox"/>
Protection box for remote control	<input type="checkbox"/>
Ex-proof, Zone II 2 G Ex de IIB T3 (other on request)	<input type="checkbox"/>
Additional electric cabinet heater	<input type="checkbox"/>
Alternative cabinet size / material / surface protection	<input type="checkbox"/>
HYDRAULIC SYSTEM	
Stainless steel fittings and hose fittings	<input type="checkbox"/>
HPU heater	<input type="checkbox"/>
PAINTING SPECIFICATION	
Norsok M-501 system (Viking Norsafe Doc. No. TSS-0030)	<input type="checkbox"/>
Other painting system and final color	<input type="checkbox"/>
SPARE PARTS	
Spare parts for Startup / Commissioning	<input type="checkbox"/>
Spare parts for Onboard spare	<input type="checkbox"/>
Spare parts for 1 year	<input type="checkbox"/>
Spare parts for 2 years	<input type="checkbox"/>
DOCUMENTATION	
Factory acceptance test procedure	<input type="checkbox"/>
Factory acceptance test report	<input type="checkbox"/>
Inspection and test plan	<input type="checkbox"/>



**VIKING
NORSAFE**

VIKING Project No.: Standard

VIKING Doc. No.: TSD-0476

Rev. Date: 14.04.2020

Rev. No: 2

Shipping, handling and lifting procedure	<input type="checkbox"/>
Packing & unpacking procedure	<input type="checkbox"/>
Commissioning procedure	<input type="checkbox"/>
TAG list	<input type="checkbox"/>
Winch drawing	<input type="checkbox"/>
Noise test report	<input type="checkbox"/>
Weight and COG datasheet	<input type="checkbox"/>
Weighing report/certificate	<input type="checkbox"/>
Other drawings/documentation/procedures	<input type="checkbox"/>

5. POSSIBLE BOAT FITTING THIS DAVIT SYSTEM

The Viking Norsafe boats fit the NRB-40 MKII davit types and variants.

Mako-655	Merlin-615
Magnum 750	(Others on request)

6. YARD SUPPLY / RESPONSIBILITY

Transport	Depending on contract
Deck foundations / reinforcement	
Assembly, erection and welding to deck	
Wire installation on winch, routing on davit and termination	
Hydraulic oil filling	
All cables to starter cabinet and agreed interface	
Testing according to regulation after installation onboard	
Preservation and maintenance after davit arrived yard and installed	



VIKING Project No.: Standard

VIKING Doc. No.: TSD-0476

Rev. Date: 14.04.2020

Rev. No: 2