

**NDA-25 HST Rescue Boat Davit**  
**Technical data:**

Davit weight: Approx. 2500 kg  
 Davit SWL: 2800 kg  
 Wire diameter: 13 mm  
 Max. launching height: 38.8 m  
 Hoisting speed: Min. 48 m/min  
 Lowering speed: Not less than that obtained from the formula  $S=0.4+0.02H$ , and not exceed 1.3 m/s.  
 Auto tension system: Pull force approx 10% of SWL  
 Auto tension speed: 0-120 m/min

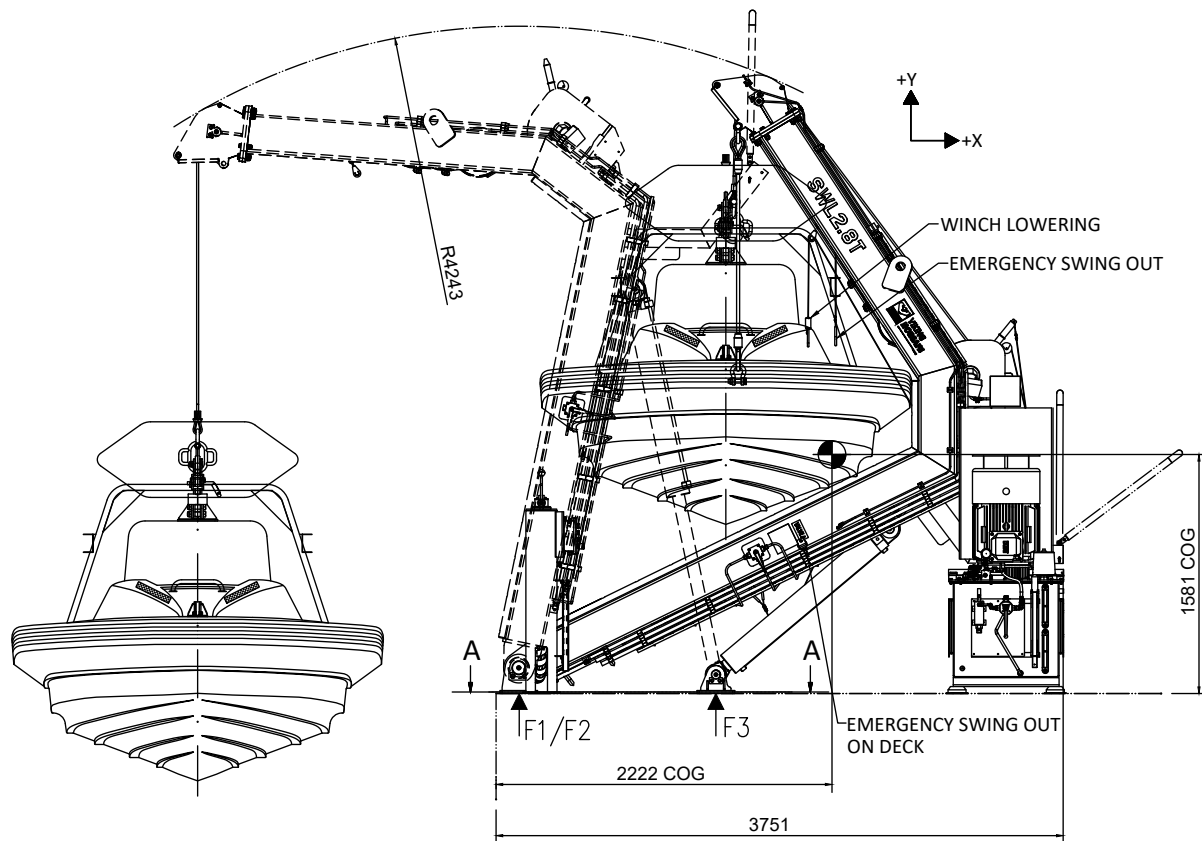
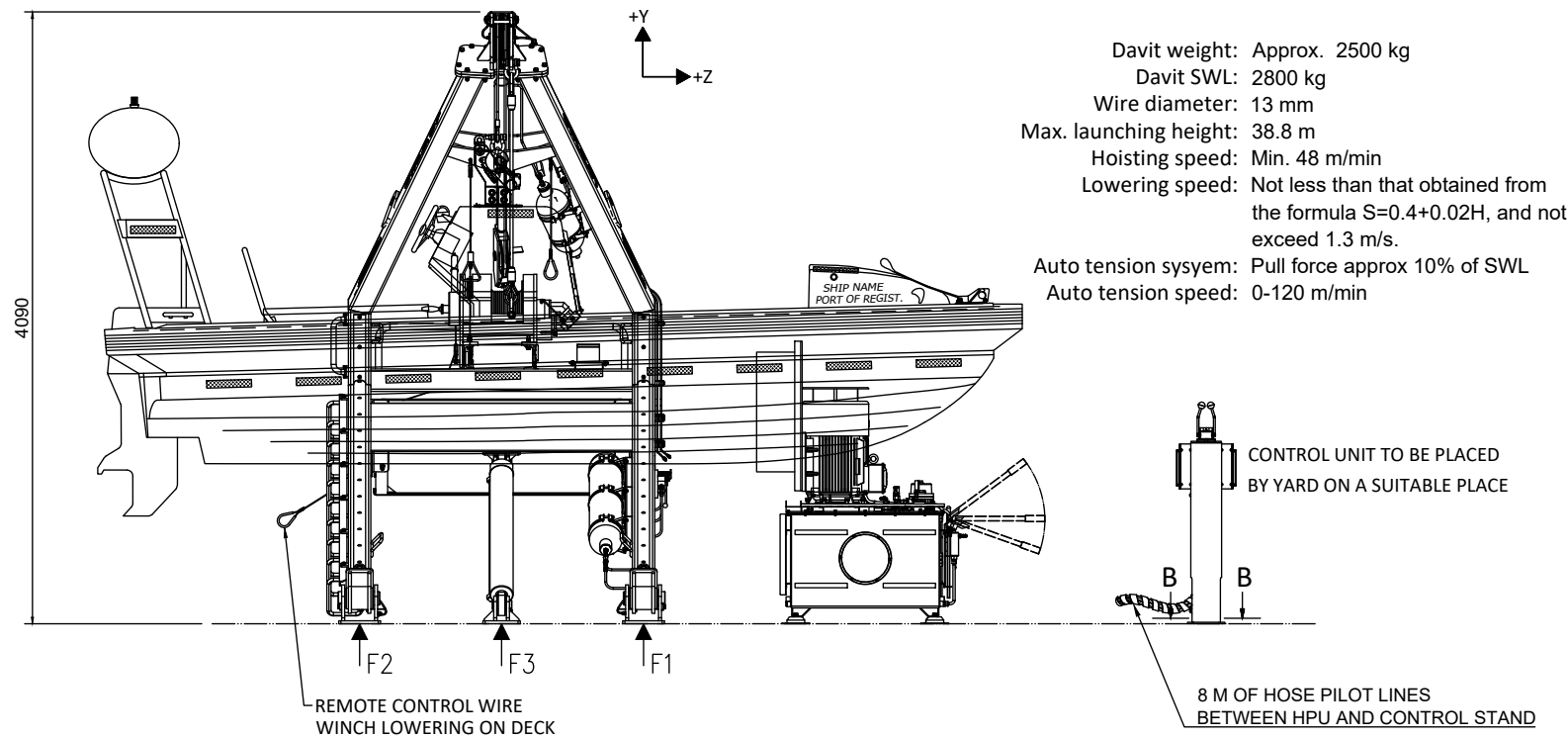

**NOTES:**

1. EMBARKATION PLATFORMS, LADDERS ETC.: YARD SUPPLY.
2. LOCATION OF HYDRAULIC POWER UNIT TO BE DECIDED BY YARD.
3. VIKING NORSAFE DELIVER 5M HOSES FOR CONNECTION BETWEEN DAVIT AND HPU. HYDRAULIC PIPING BETWEEN HPU AND DAVIT IS YARD SUPPLY.
4. CONNECTION OF MAIN POWER SUPPLY TO EL. CABINET IS YARD SUPPLY.
5. ALL FIELD WELDS TO BE PERFORMED ACC.TO APPROVED WPS. (YARD RESPONSIBILITY). ALL FIELD WELDING IS SUBJECT TO CLASS APPROVAL PRIOR TO START WELDING.

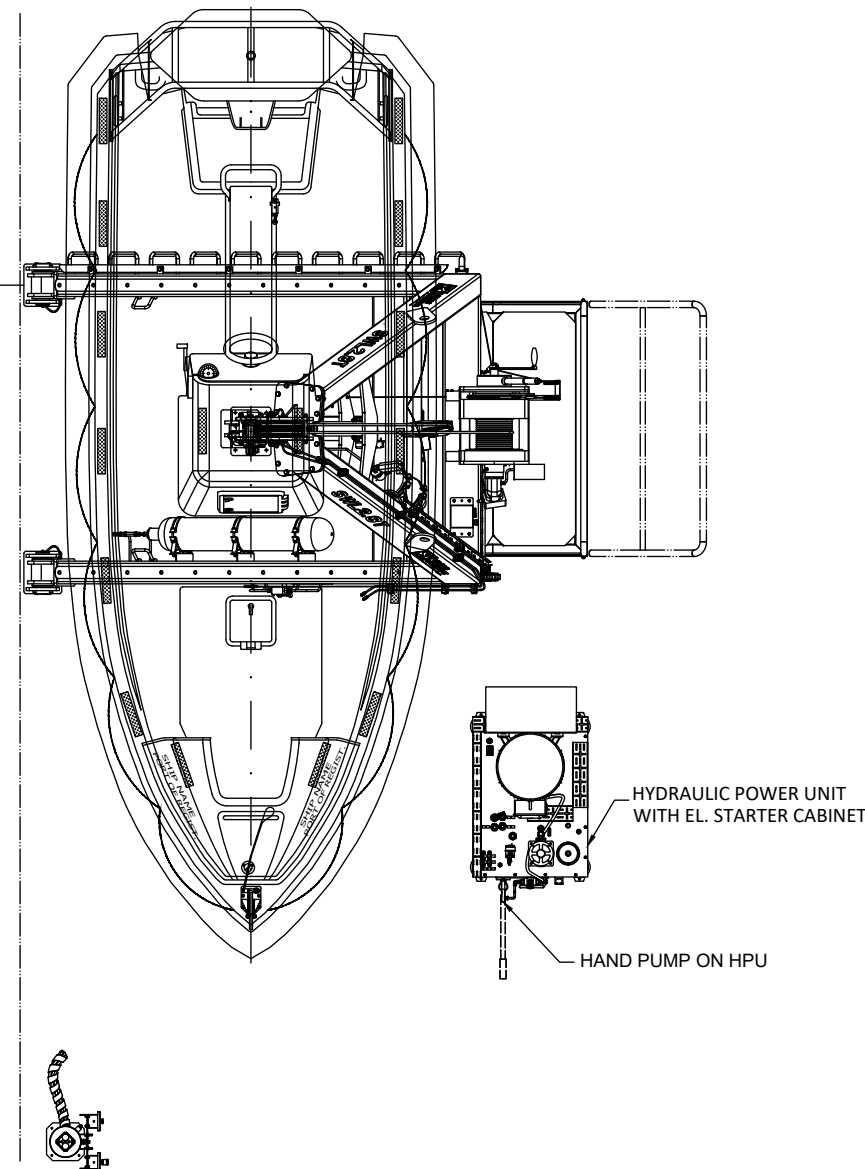
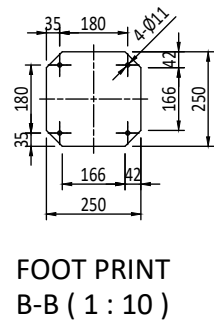
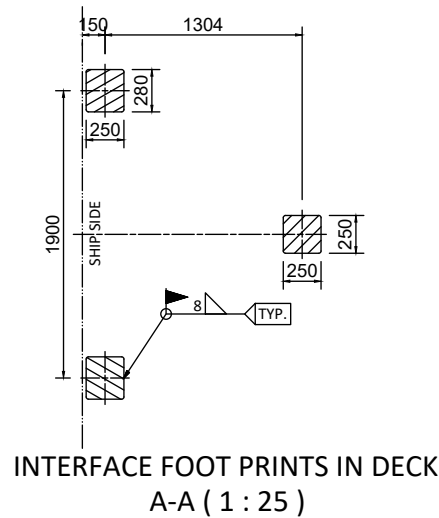

REV	DESCRIPTION	BY	CHECK	APPRO	DATE
1	Re-issued for approval	DZH	GACA	WAGU	25.03.2021
0	Issued for construction	CENI	GACA	WAGU	28.10.2019

		VIKING Norsafe Life-Saving Equipment Norway AS P.O Box 115 Tel: +47 37 05 85 00 4852 Færвик Fax: +47 37 05 85 01 NORWAY 24/7 Service: +47 37 05 63 33 Email: Viking-Norsafe@viking-life.com	
Drawn by	Check by	Appr. by	Initial release date
GACA	GACA	WAGU	28.10.2019

Project number	Project name	Client number

Title		Material Number
NDA-25 HST Rescue boat davit for Merlin-615 (Outboard)		
Weight		N/A
Projection method		
Drawing type	Tolerances	Scale
GA	ISO 2768-mK, ISO 13920-BF	1:50
Drawing Number		Sheet Size
G-503534		A3
Revision		Sheet No.
1		1/1