

Viking Norsafe HD-52 Free Fall Lifeboat Davit

Weight Davit :	35 000 kg
SWL lowering:	29 000 kg
SWL hoisting:	29 000 kg
Lowering velocity 0-50% load:	12 m/min
Lowering velocity 50-100% load:	12 m/min
Hoisting velocity 0-50% load:	12 m/min
Hoisting velocity 50-100% load:	12 m/min
Standard lifeboat weight emty lifeboat:	21 840 kg
Standard lifeboat weight fully loaded 70 Persons @ 100kg:	28 840 kg
Design Specification:	17° list, 17° trim
Primary means of launching:	Free fall 17° list, 17° trim
Retrieval / secondary launching :	Lowering by winch 5° list, 2° trim (Power must be available)

Steel

Primary structural steel: Ref. TSM-0021
 Secondary (outfitting) steel: Ref. TSM-0021

Grating

Grating and grating steps in GFRP (Glass Fiber Reinforced Plastic)



Design for davit

Davit design according to NORSOK R-002 & SOLAS

Design for Stairs, Railing & Walkways

Stairs, Handrails & Walkways for platforms according to ISO 14122

REV	DESCRIPTION	BY	CHECK	APPRO	DATE
1	CHANGED TO VIKING NORSAFE LOGO	BEN	CMH	GNI	12.09.2019
0	ISSUED FOR INFORMATION	CMH	GNI	GNI	25.01.2018

 VIKING NORSAFE <small>LIFE-SAVING EQUIPMENT</small>		VIKING Norsafe Life-Saving Equipment Norway AS P. O. Box 115 Tel: +47 37 05 85 00 4852 Faervik Fax: +47 37 05 85 01 NORWAY 24/7 Service: +47 37 05 63 33 Email: Viking-Norsafe@viking-life.com
DWG SIZE: A3 SCALE: 1:125 COPY OF:		PART NO. WEIGHT: SHEET: 1 / 2
CLIENT NO:	PROJECTION METHOD:	HD-52
TOLERANCES: ISO 2768-mk, ISO 13920-BF		FREE FALL DAVIT
DWG No: G-502420	REVISION: 1	GENERAL ARRANGEMENT
	PROJECT:	

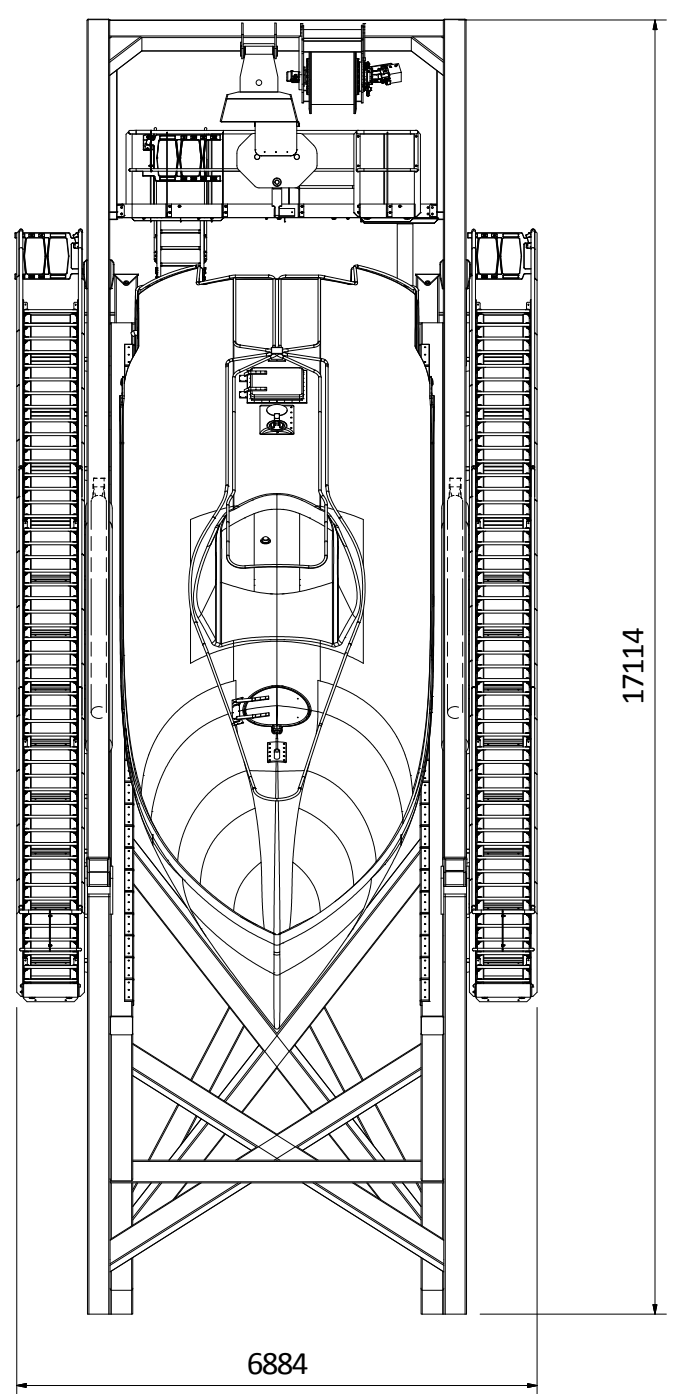
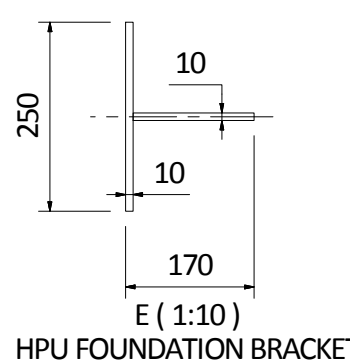
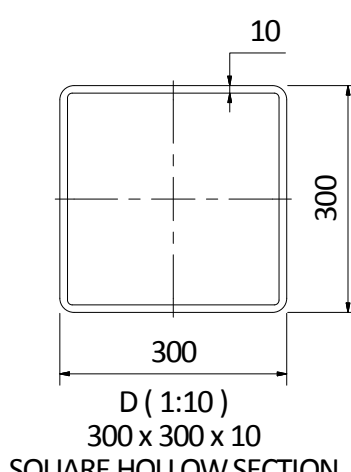
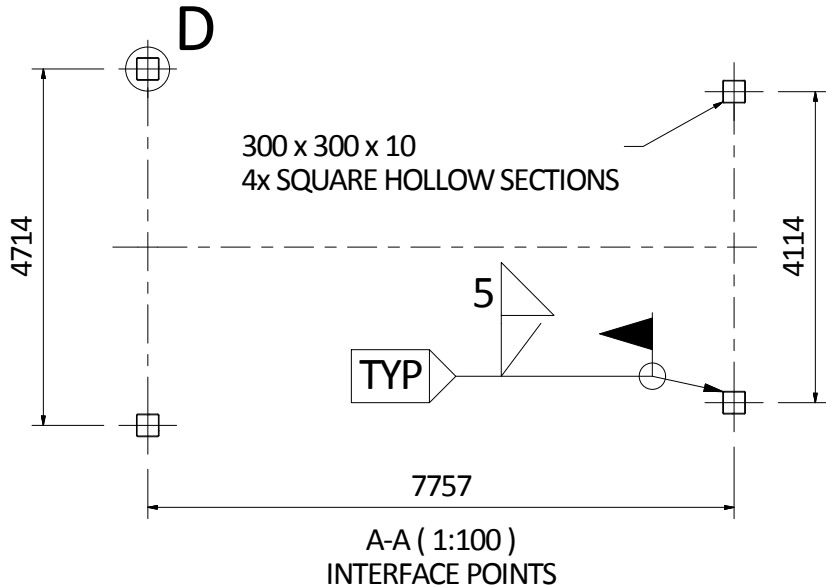
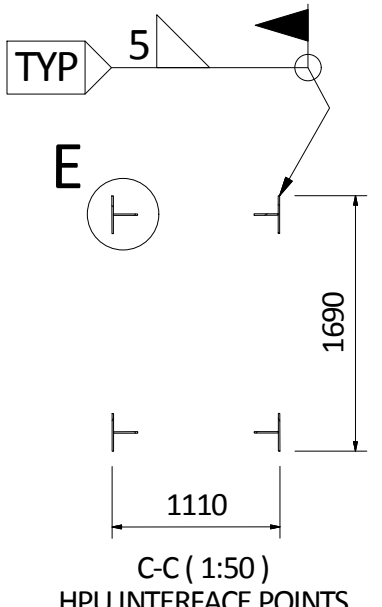
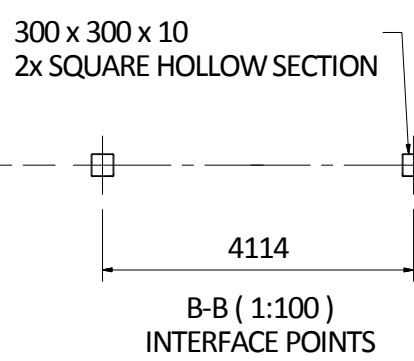
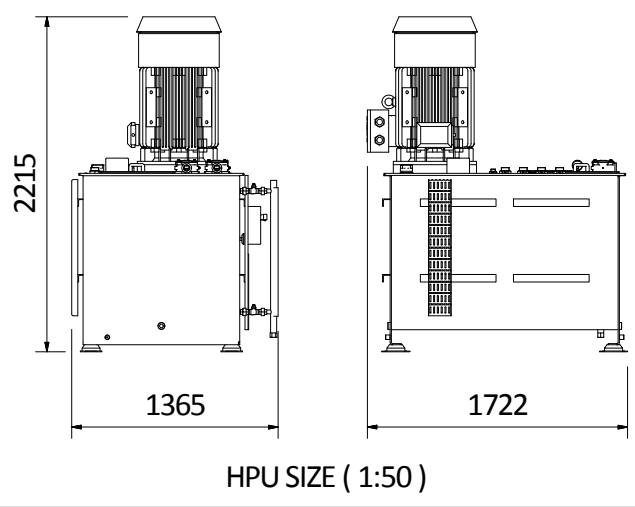
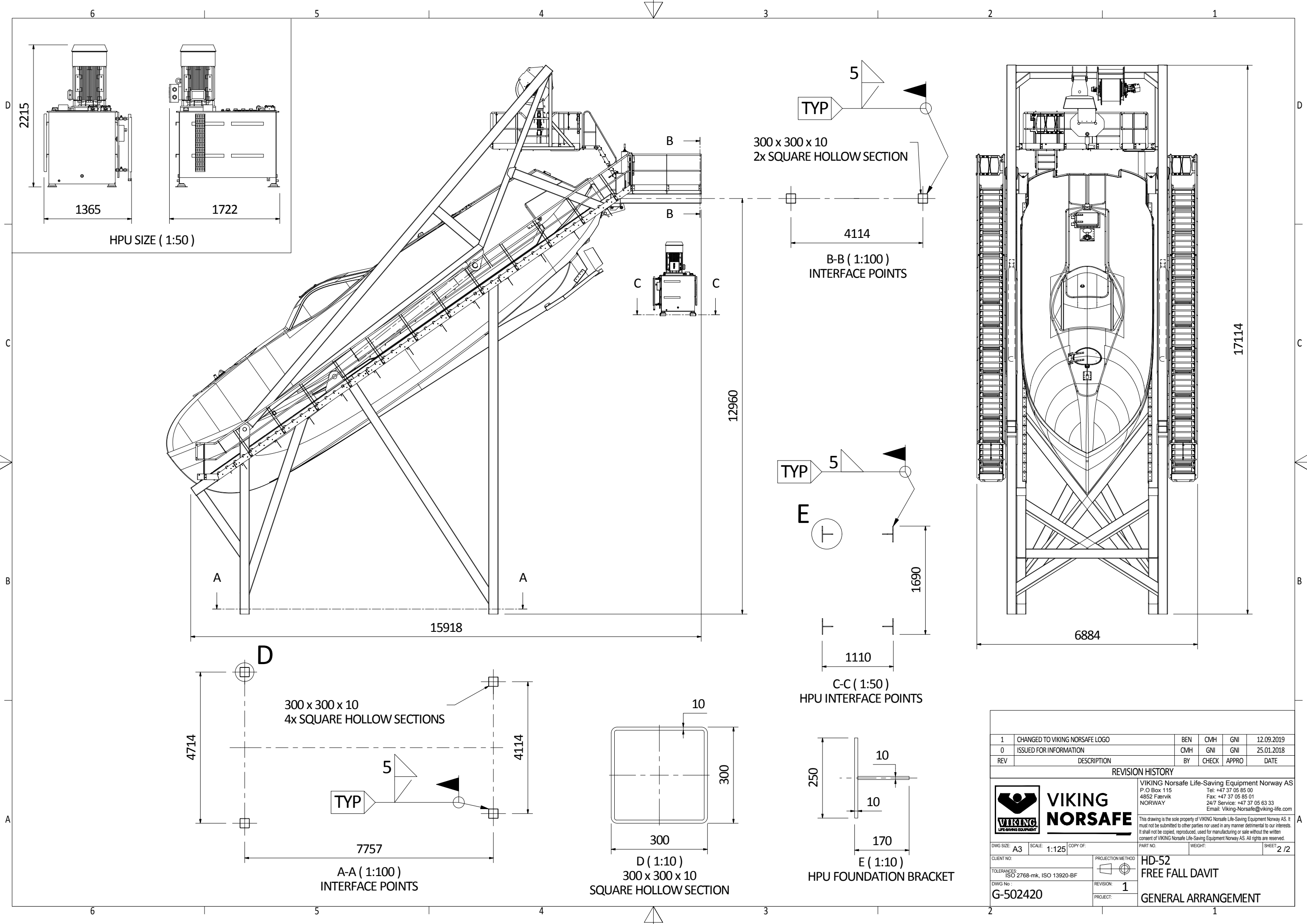

REV	DESCRIPTION	BY	CHECK	APPRO	DATE
1	CHANGED TO VIKING NORSAFE LOGO	BEN	CMH	GNI	12.09.2019
0	ISSUED FOR INFORMATION	CMH	GNI	GNI	25.01.2018

REVISION HISTORY

		VIKING NORSAFE <small>VIKING NORSAFE LIFE-SAVING EQUIPMENT</small>	
VIKING Norsafe Life-Saving Equipment Norway AS P. O. Box 115 4852 Færøvik NORWAY		Tel: +47 37 05 85 00 Fax: +47 37 05 85 01 24/7 Service: +47 37 05 63 33 Email: Viking-Norsafe@viking-life.com	
<small>This drawing is the sole property of VIKING Norsafe Life-Saving Equipment Norway AS. It must not be submitted to other parties nor used in any manner detrimental to our interests. It shall not be copied, reproduced, used for manufacturing or sale without the written consent of VIKING Norsafe Life-Saving Equipment Norway AS. All rights are reserved.</small>			
DWG SIZE: A3	SCALE: 1:125	COPY OF:	PROJECTION METHOD:
CLIENT NO:	TOLERANCES: ISO 2768-mk, ISO 13920-BF	DWG No: G-502420	REVISION: 1
PART NO:		WEIGHT:	SHEET: 2 / 2
PROJECT: HD-52 FREE FALL DAVIT			GENERAL ARRANGEMENT