

ELEVATION

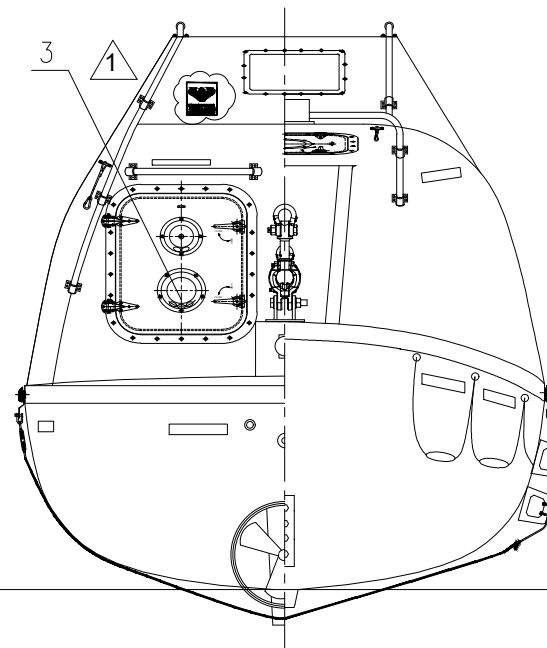

REAR/FRONT VIEW

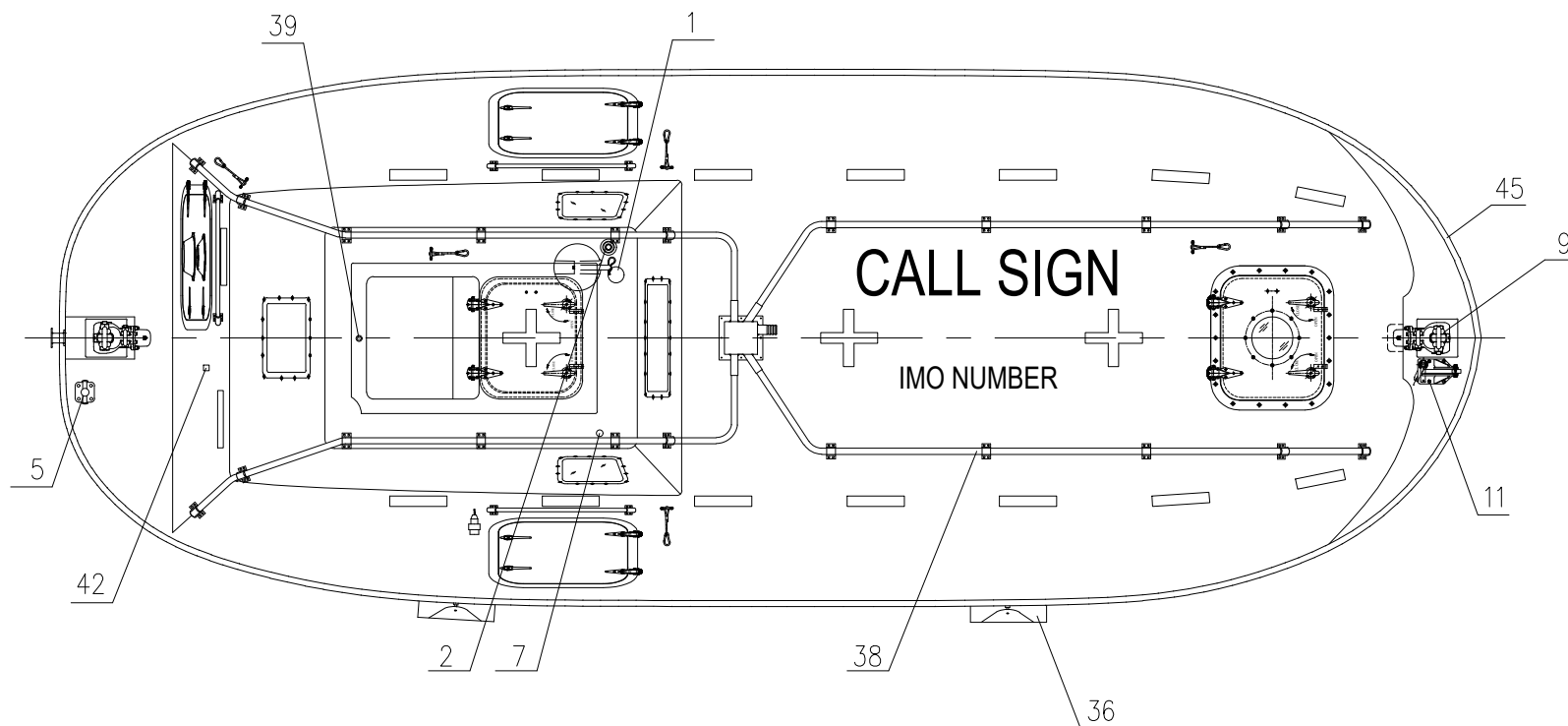

PLAN (BOAT SHOWS PORT SIDE BOAT)

MAIN PARTICULARS

LENGTH (MOULDED)	7.35M / 7.52M (Including fender)
BREADTH (MOULDED)	2.68M / 2.82M (Including fender)
DEPTH	1.05M
HEIGHT (TOTAL)	3.00M
HOOK DIST	7.00M
NO. OF PERSON	52P
CRAFT WEIGHT	3410KG
SPEED	>6 KNOTS
TOTAL WEIGHT	7700KG (82.5kg/pers)
ENGINE	380J-3 BUKH DV 24 RME BUKH DV 29 RME

NO.	REF.DWG.NO.	DESCRIPTION	QTY.	REMARKS
48		HYDRAULIC PUMP OR TANK	1	
47		ACCUMULATOR	1	
46		PILOT CONTROLLED VALVE	1	
45		FENDER	4	RUBBER
44		OPERATION PANEL	1	
43		PLUG FOR BATTERY CHARGING	1	IP56
42		VENT FOR BATTERIES	1	SS 316 & PVC HOSE
41		WATER SENSOR UNIT	1	
40		EMERGENCY RELEASE VALVE	1	
39		RAIN COLLECTION	1	BRASS
38		SPRINKLER OUTLET/PIPING	1 LOT	AIISI 316
37		EMERGENCY STEERING HANDLE	1	HOT DIPPED GALVANIZED STEEL
36		SKATE	2	RUBBER & ALUM. PLATE
35		RAIL	3	AIISI 316
34		FOOD COMPARTMENT	1	
33		OAR/CRUTCH	2	
32		WATER COMPARTMENT	3	F.R.P. WATER TIGHT
31		STEERING GEAR	1	
30		ENGINE & PROPELLER SHAFT	1	
29		STEERING NOZZLE & PROPELLER	1	F.R.P./NiMn-Bronze Cu3-Cu4
28		BATTERIES	2	70AH
27		AXE	2	
26		PILLAR	1	F.R.P.
25		SPRINKLE SYSTEM	1 LOT	
24		DRAIN PLUG	1	BRASS
23		MANUAL PUMP	1	
22		FIRE EXTINGUISHER	1	
21		FUEL TANK	1	SEA WATER RESISTANT ALUM.
20		AIR SUPPLY SYSTEM	1 LOT	
19		SAFETY BELT	1/PERS	
18		EQUIPMENT COMPARTMENT	1	
17		DOOR LATCH	1 LOT	SS316 & PVC SHIELD WIRE ROPE
16		BACK REST	1 LOT	PLYWOOD (18MM THK.x400MM H.)
15		CONTROL PANEL	1	
14		SEARCH LIGHT	1	
13		INT. LIGHT	2	
12		HELMS CHAIR	1	F.R.P.
11		PAINTER HOOK	1	SS2377
10		GRIPING BOBBIN	2	HOT DIPPED GALVANIZED STEEL
9		HOOKS DEVICE ARRANGEMENT	2	DIB 75
8		LIFE LINE	2	PVC SHIELD WIRE ROPE
7		REMOTE CONTROL LINE HOLE	1	
6		DOOR	1 LOT	
5		BOLLARD	1	SS 316
4		REFLECT LIGHT STRIP	1 LOT	
3		VENTILATOR	2	
2		POSITION LIGHT	1	
1		RADAR REFLECTOR	1	

1	USE NEW TEMPLATE	KARL	PHLI	THWA	12.06.2019
REV	DESCRIPTION	BY	CHECK	APPRO	DATE

REVISION HISTORY

VIKING NORSAFE

VIKING Norsafe Life-Saving Equipment Norway AS
 P.O. Box 115 Tel: +47 37 05 85 00
 4852 Færøvik Fax: +47 37 05 85 01
 NORWAY 24/7 Service: +47 37 05 63 33
 Email: Viking-Norsafe@viking-life.com

Drawn by	Check by	Appr. by	Initial release date
KARL	PHLI	THWA	11.06.2018

Project number	Project name	Client number
Standard		
Title		Material Number
EXTERNAL ARRANGEMENT		Weight
DIB 75		Projection method
JYN-74T		
Drawing type	Tolerances	Scale
GA	ISO 2768-mK, ISO 13920-BF	1:30
Drawing Number	Revision	Sheet Size
G-502649	1	A3
		Sheet No.
		1/1

Due to manufacturing reasons dimensions may vary up to 50mm