

6 5 4 3 2 1

D

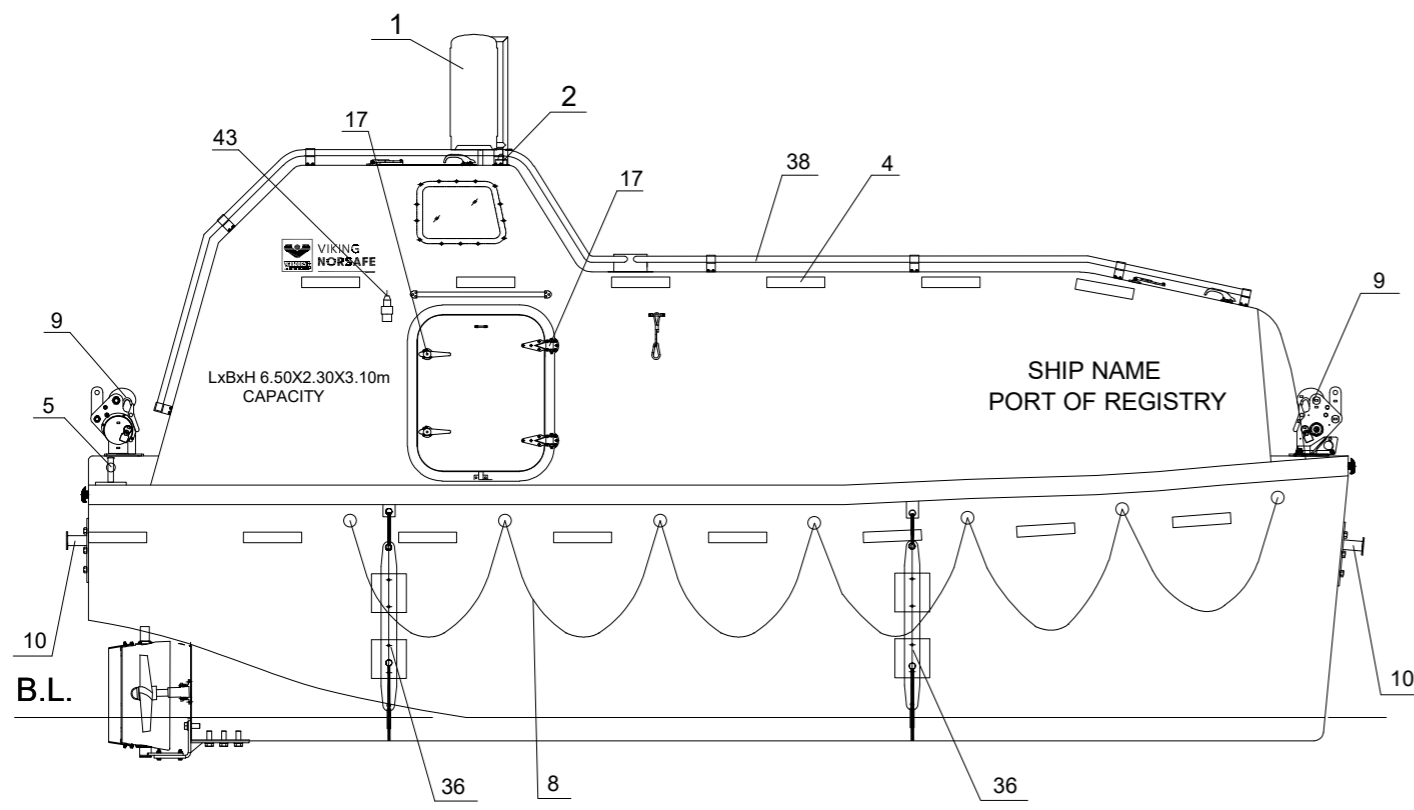

ELEVATION

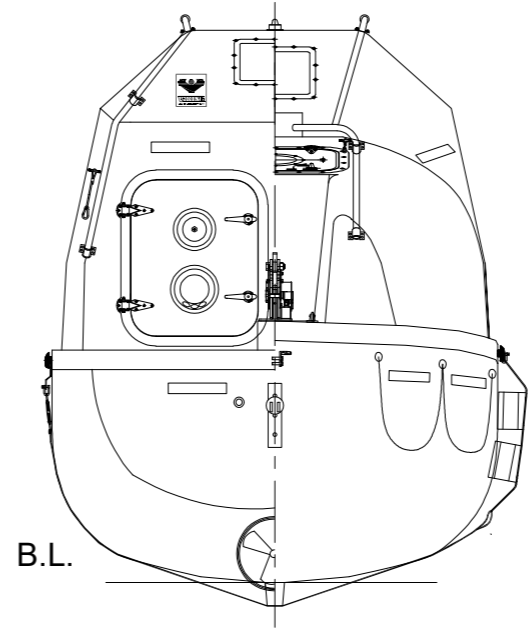

REAR/FRONT VIEW

PRINCIPAL DIMENSIONS

LENGTH (MOULDED)	6.50m
BREADTH (MOULDED)	2.30m
HEIGHT	3.10m
DEPTH MOULDED	1.20m
HOOK DIST	6.08m
CAPACITY	36 PERSONS
WEIGHT OF BOAT WITH EQUIPMENT	2930Kg
WEIGHT OF BOAT WITH PERSONS	5900Kg (82.5kg/pers)
SPEED	>6Kn
ENGINE	380J-3
	BUKH DV 24
	(USCG) BUKH EPA 28

C

B

A

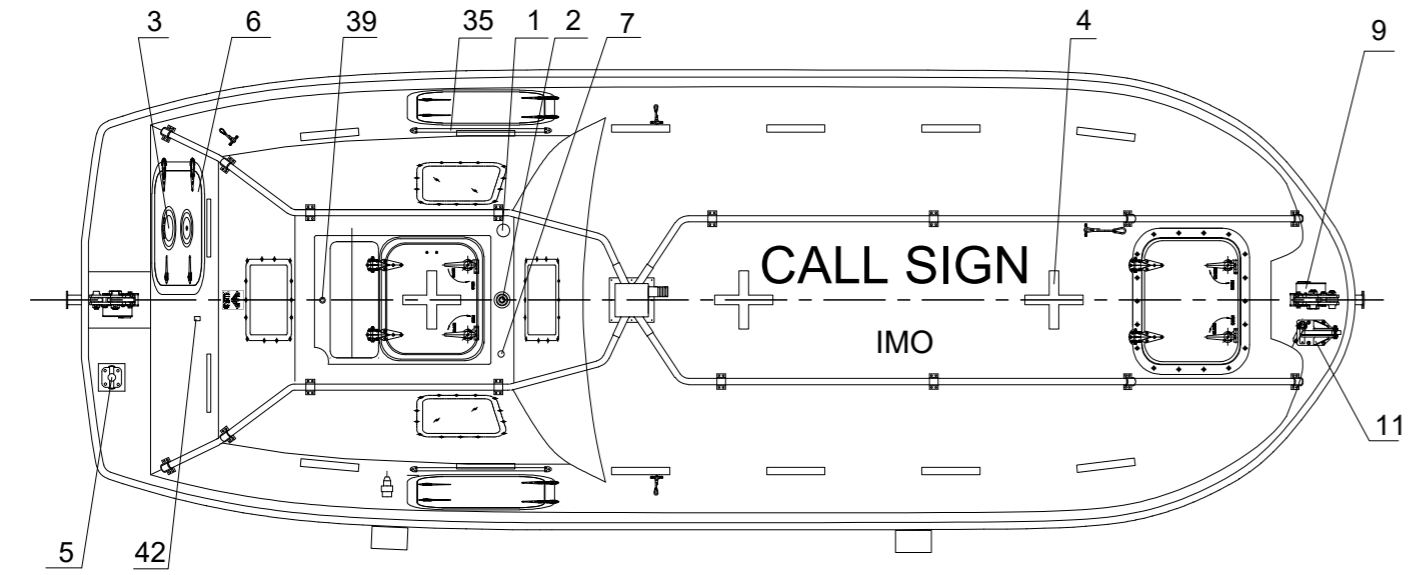

PLAN

NO.	REF.DWG.NO.	DESCRIPTION	QTY.	REMARKS
44		BRACKET FOR RELEASE UNIT	1	AISI 316L
43		PLUG FOR BATTERY CHARGING	1	IP67
42		VENT FOR BATTERIES	1	SS 316 & PVC HOSE
41		HYDROSTATIC UNIT	1	
40		RELEASE MECHANISM	1	AISI 316
39		RAIN COLLECTION	1	BRASS
38		SPRINKLE OUTLET/PIPING	1 LOT	SEA WATER RESISTANT ALUM.
37		EMERGENCY STEERING HANDLE	1	HOT DIPPED GALVANIZED STEEL
36		SKATE	2	RUBBER & ALUM.
35		RAIL	2	STAINLESS STEEL
34		FOOD COMPARTMENT	1	F.R.P.
33		OAR/CRUTCH	2	WOOD
32		WATER COMPARTMENT	3	F.R.P. WATER-RESISTANT
31		STEERING GEAR	1	
30		ENGINE & PROPELLER SHAFT	1	
29		STEERING NOZZLE & PROPELLER	1	F.R.P./NIMn-Bronze Cu3-Cu4
28		BATTERIES	2	70AH
27		AXE	2	
26		PILLAR	1	
25		SPRINKLE PUMP	1	
24		DRAIN PLUG	1	BRASS
23		MANUAL PUMP	1	
22		FIRE EXTINGUISHER	1	
21		FUEL TANK	1	SEA WATER RESISTANT ALUM.
20		AIR CYLINDER	3	
19		SAFETY BELT	1/PERS	
18		EQUIPMENT COMPARTMENT	2	
17		DOOR LATCH AND HINGE	1 LOT	SS316 & PVC SHIELD WIRE ROPE
16		BACK REST	1	PLYWOOD
15		CONTROL PANEL	1	
14		SEARCH LIGHT	1	
13		INT. LIGHT	2	
12		HELMSMANS CHAIR	1	F.R.P.
11		PAINTER HOOK	1	HOT DIPPED GALVANIZED STEEL
10		Backing plate with bobbin	2	SS2377
9		HOOKS DEVICE ARRANGEMENT	2	TOR-MK2-S 3.36T
8		LIFE LINE	2	
7		REMOTE CONTROL LINE HOLE	1	
6		DOOR	1 LOT	
5		BOLLARD	1	SS 316
4		REFLECT LIGHT STRIP	1 LOT	
3		VENTILATOR	2	
2		POSITION LIGHT	1	
1		RADAR REFLECTOR	1	

REV	DESCRIPTION	BY	CHECK	APPRO	DATE
2	Use new template	KAYU	KARL	THWA	20.06.2019
1	Updated positon of aft door	SATA	VXI	THWA	27.11.2015

REVISION HISTORY

	VIKING NORSAFE LIFE-SAVING EQUIPMENT	VIKING Norsafe Life-Saving Equipment Norway AS P.O Box 115 4852 Faervik NORWAY Tel: +47 37 05 85 00 Fax: +47 37 05 85 01 24/7 Service: +47 37 05 63 33 Email: Viking-Norsafe@viking-life.com
	Drawn by: VX Check by: THWA Appr. by: TMA Initial release date: 05.05.2015	

Project number Standard	Project name	Client number
Title EXTERNAL ARRANGEMENT		Material Number
Title TOR MK2-S 3.36T		Weight
Title JYN-65T		Projection method
Drawing type GA	Tolerances ISO 2768-mK, ISO 13920-BF	Scale 1:40
Drawing Number G-500791		Sheet Size A3
		Revision 2
		Sheet No. 1/1

Due to manufacturing reasons dimensions may vary up to 50mm
Port side shown, Starboard side is Mirrored

6 5 4 3 2 1