

Cradle Number	Complete Number with lashing	Surface Finished
1004360	1002727	Galvanized
1055772	1055771	Custom Spec. Galvanized
1066092	1066093	Stainless Steel

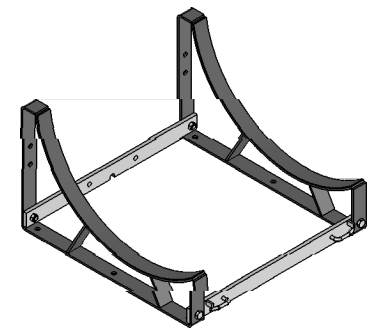
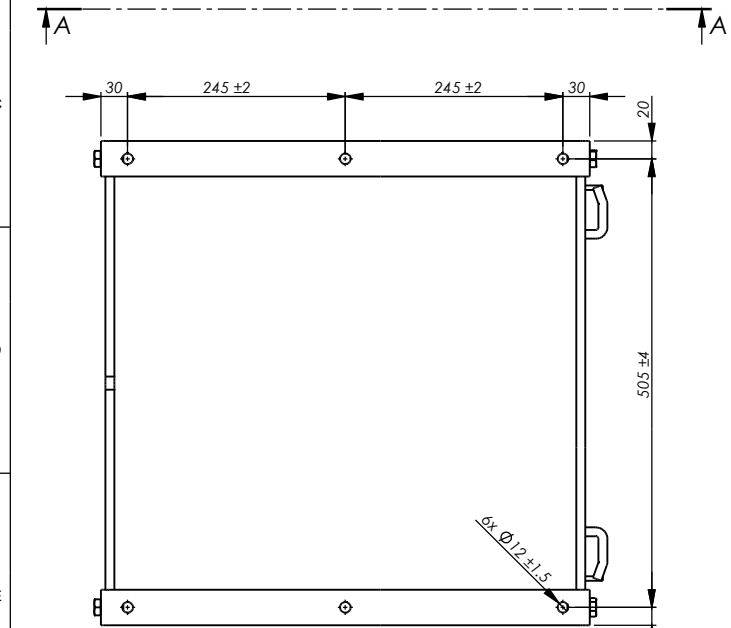

Measures without tolerance ± 3 mm

If the product is requested to be manufactured differently, this MUST be approved by VIKING LIFE-SAVING EQUIPMENT A/S and a specification of change must be filled in if the alteration is approved. Unless otherwise specified the product must always be clearly labelled with Viking part no., manufacturer ID and manufacturing year.

MATERIAL NO: See Table	Old DWG No:	STATUS: FR	UNITS: mm/kg	WEIGHT: 9500	CHECK DATE/INIT: 20180529/PSOM
BASIC MATERIAL:	SURFACE TREATMENT:		SHEET SIZE: A3	SCALE: 1:5	SHEET NO: 1/1
			DRAWN DATE/INIT: 20180529/PSOM		

<p>VIKING LIFE-SAVING EQUIPMENT A/S Sødding Ringvej 13, DK-6710 Esbjerg V Tel.: +45 7611 8100 Fax.: +45 7611 8101 E-mail: viking@viking-life.dk Web: www.VIKING-life.com</p>	<p>PROJECTION TYPE FIRST ANGLE PROJECTION GENERAL TOLERANCE:</p>	DESCRIPTION:
		<p>Cradle for DKF rafts 12 DKF</p>

Issue /ref. no	DATE	APPROVED
REVISIONS		

Copyright of VIKING LIFE-SAVING EQUIPMENT DENMARK whose property this document remains. No part thereof may be disclosed, copied, duplicated or in any other way made use of except with the approval of VIKING LIFE-SAVING EQUIPMENT DENMARK.	CAD NO. : 14001009	Drawing NO. : 16004766	REV NO. : 03
--	-----------------------	---------------------------	-----------------