

Section A-A (1:2)

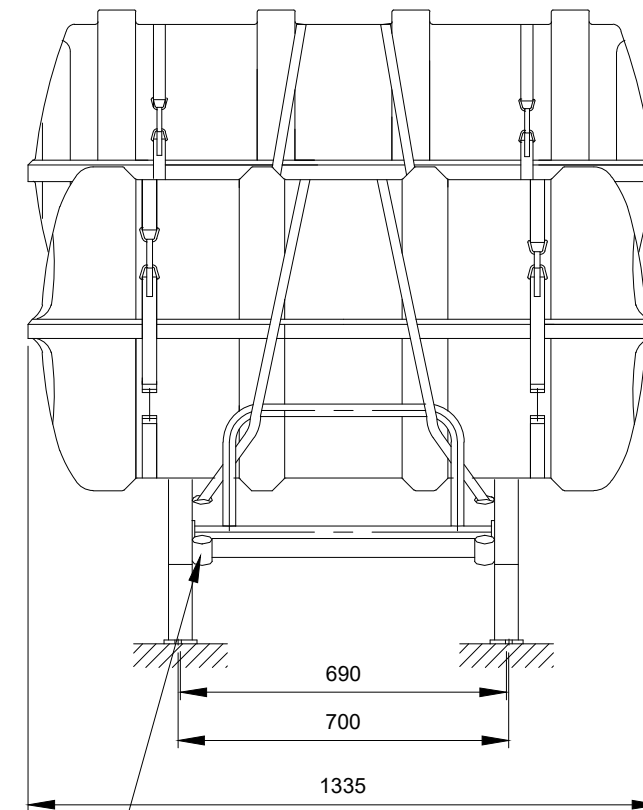

Holder for service pipe  
 Servicerør placeres i holder, mens flåderne surres. Place service pipe in holder while container is being lashed.

Part no. 1004147 Sandblasted+Primed  
 Part no. 1015722 Galvanized  
 Measures are for guidance only

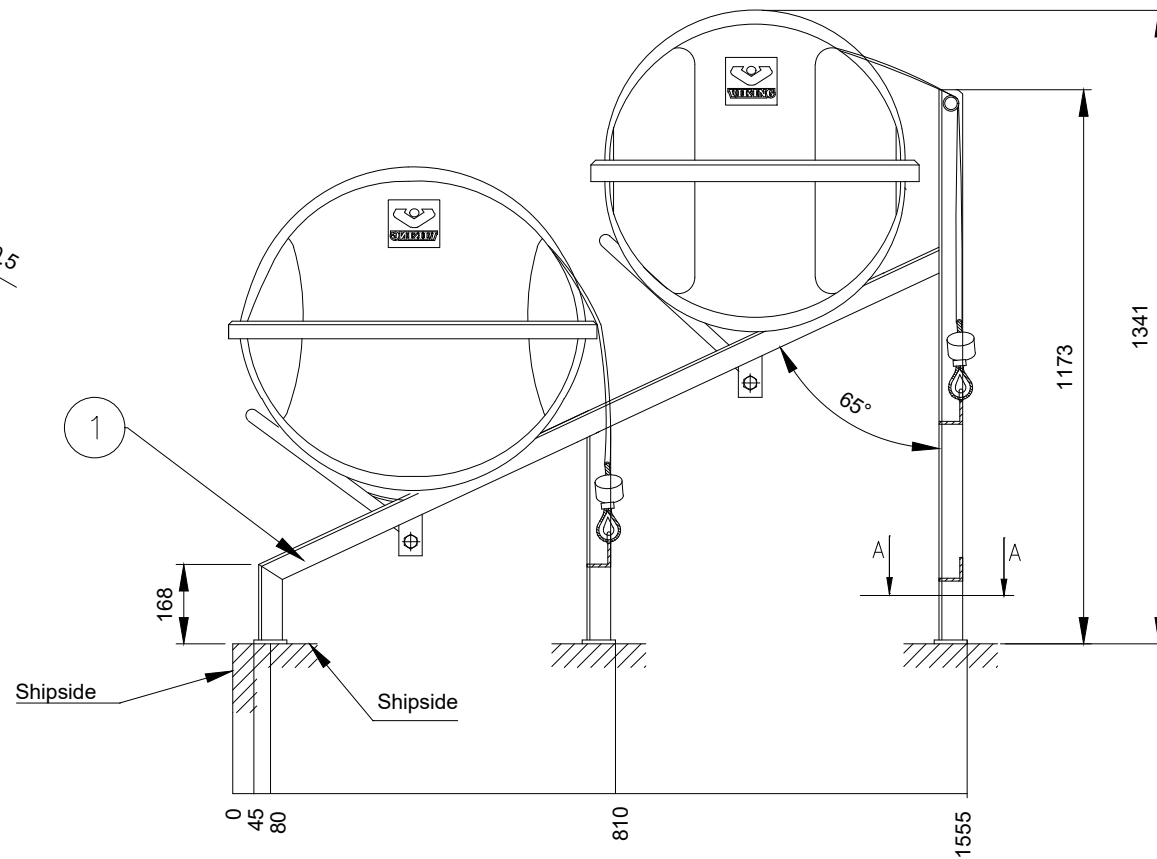
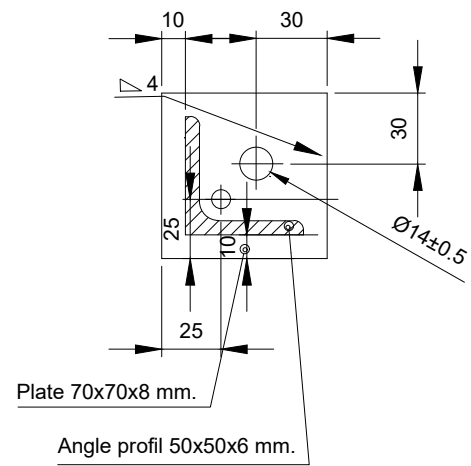
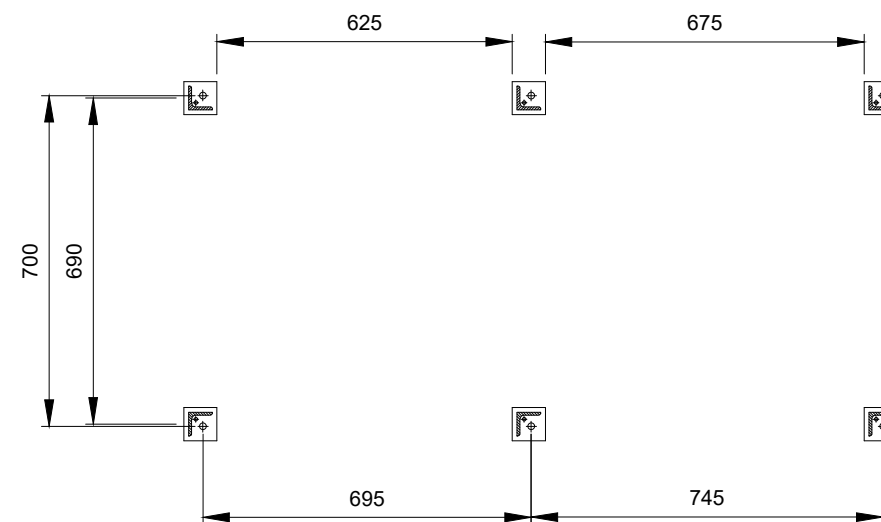

Producer of rack is responsible for weldings, dimensioning and choice of material.

016-6000	DK 25 B
016-6000	DK 20 A-B
016-5100	DK 10-16 A-B
Container Part no.:	Description:

1	1	Rampstand	16002825
POS	QTY	DESCRIPTION	MATERIAL NO.
PARTLIST			
REPLACES: 42004020			
		VIKING Life-Saving Equipment A/S Sædding Ringvej 13 Tel: +45 7611 8100 DK-6710 Esbjerg V Fax: +45 7611 8101 Denmark Email: viking@viking-life.com	
		Drawn by NTAE	Check by CAJ
Project number		Project name	
Client number			
Title <b>GA Ramp 1x16 DK+ 1x20 DK</b>			Material Number
Weight Various No.			Projection method
Drawing type <b>ASM</b>		Tolerances	Scale <b>1:16</b>
Drawing Number <b>ENG-20067418</b>		Revision <b>0</b>	Sheet Size <b>A3</b>
		Revision <b>0</b>	Sheet No. <b>1/1</b>

