

Mounting instruction for VIKING column rack

V-MI- 0194

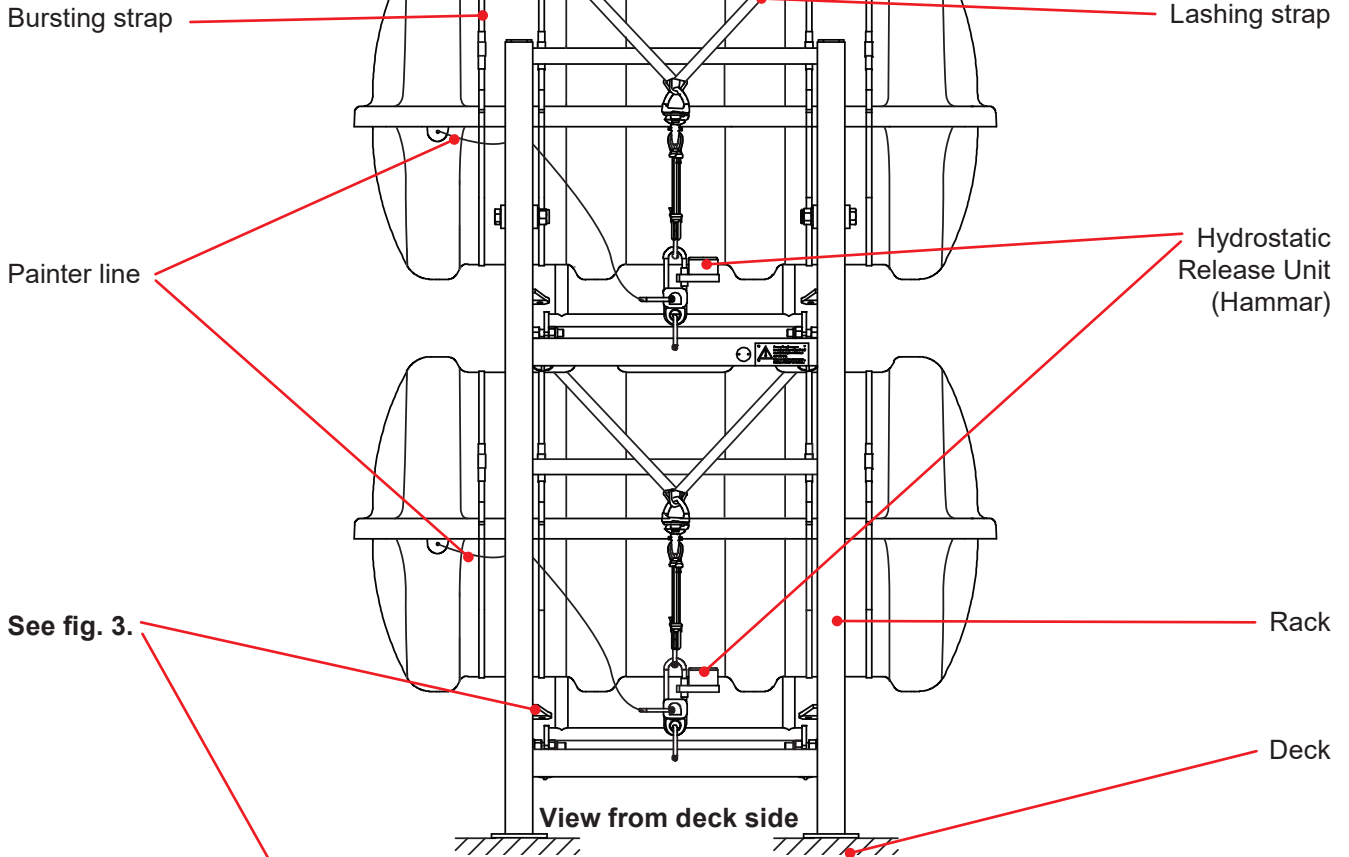

Fig. 1.



Mounting of Cell Rubber on Rack.

Fig. 2.

Cut the cell rubber to length C. and fit the cell rubber to rack as illustrated. in fig. 2. Start at top of rack pos. nr. 1.

Mark: Qty.: Length:
C 2 x 2500 mm

Having fitted the cell rubber, follow the instruction on page 3 (Thanner hydrostatic release unit).

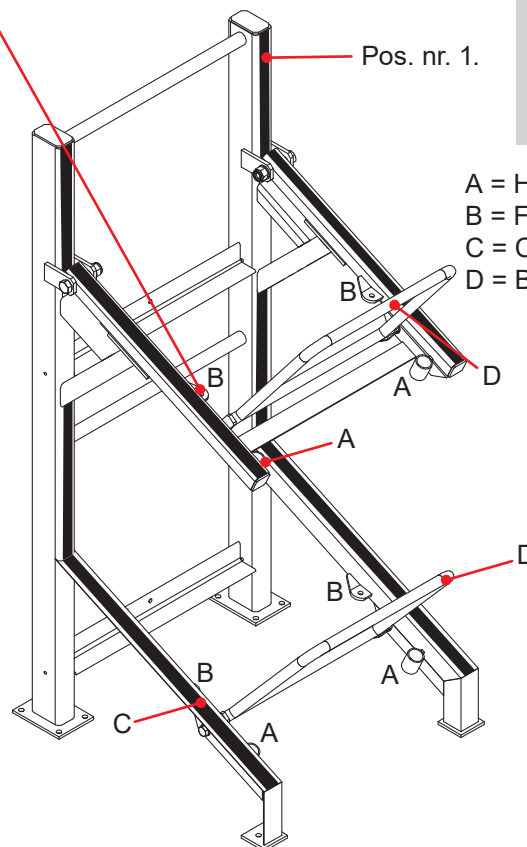

Note:

Lines, cords and lashings must be replaced if they have become frayed, damaged or decomposed.

- A = Holder for service pipe
- B = Fastening point for lashing strap
- C = Cell rubber on rack profile
- D = Beam

Mounting instruction for VIKING column rack

V-MI- 0194



Before mounting of containers

Securing of bracket

Ensure that the bracket for the upper container is properly secured before mounting of the lower container.

The lashing may be used for this purpose.

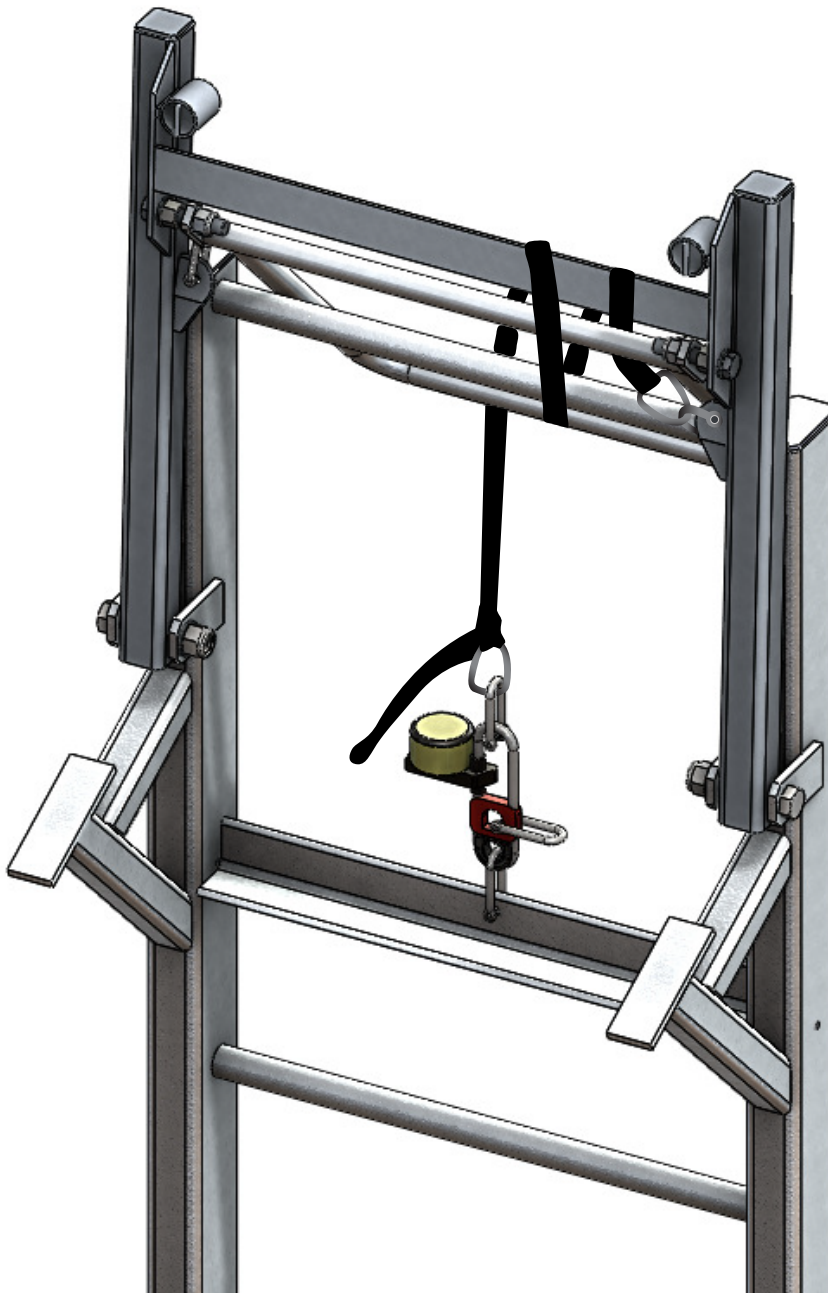

Mounting instruction for VIKING column rack

V-MI- 0194



Installation instructions:

Install the rack on the deck by means of either bolting or welding.

General guidelines for installation:

Place the container so that the raft's painter can be operated from deck (deck side). When positioning the container on rack, ensure that release of the raft is not impeded, i.e. there must be unimpeded access to the raft's painter.

1. Place the service pipes in the holders for service pipes
2. Shackle the lashing straps to the fastening points - fig. 3. Place the lashing underneath the supporting brace of the rack.
3. Place the container on the rack resting on the service pipes.
4. Attach the hydrostatic release unit to the rack.
5. Lift the lashing strap over the container so that the supporting brace touches the container. Connect the lashing to the hydrostatic release unit as illustrated on page 3.

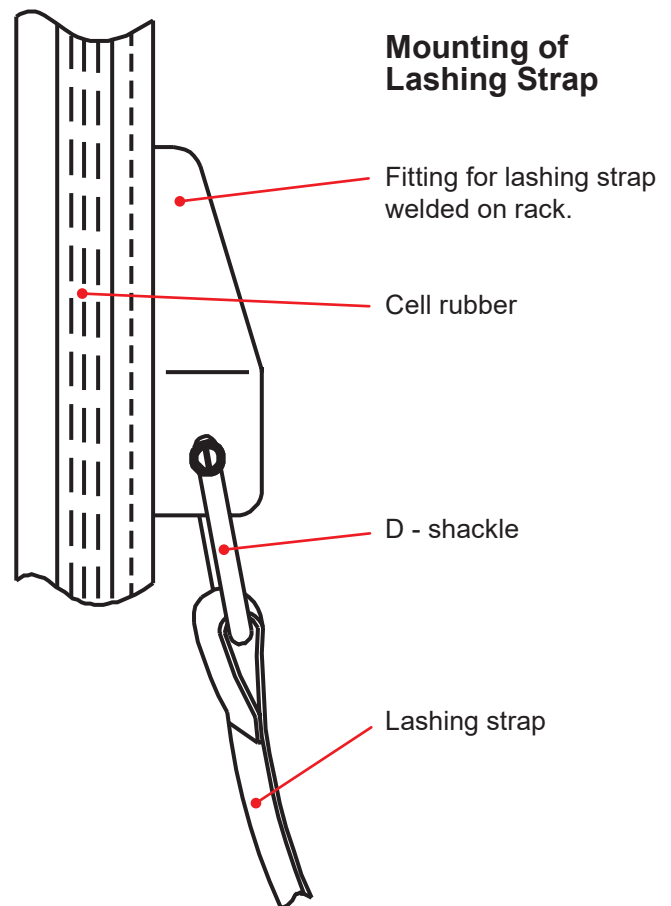
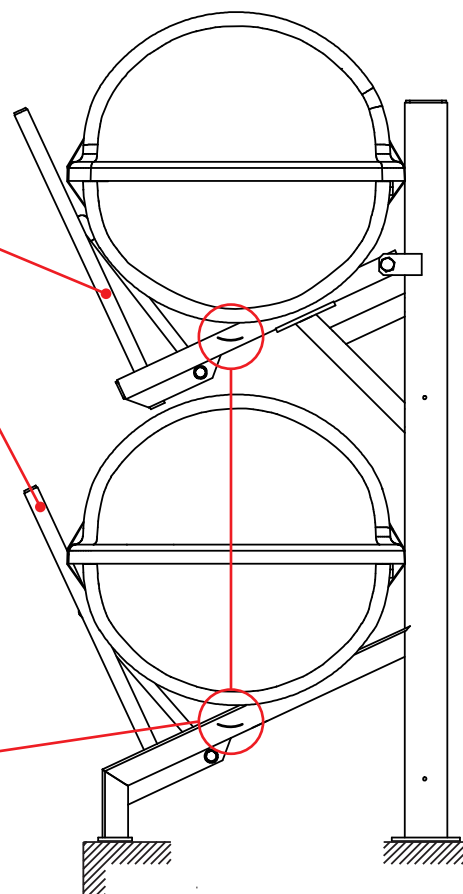

Fig. 3.



Fitting for lashing strap welded on rack.



Mounting instruction for VIKING column rack

V-MI- 0194



Mounting Instructions for Hydrostatic release unit type Hammar.

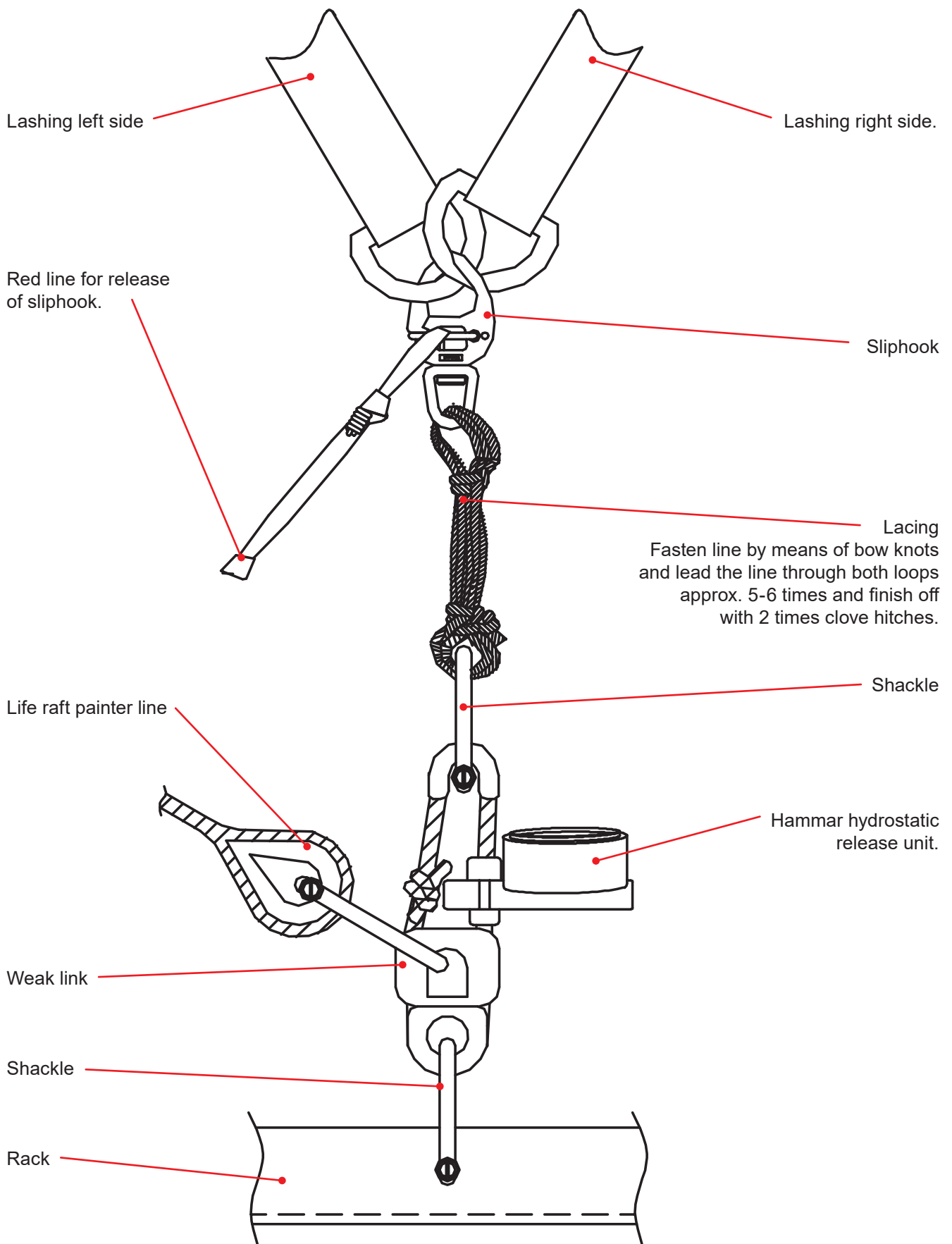

Mounting instruction for VIKING column rack

V-MI- 0194



Mounting of release unit type HAMMAR with remote release

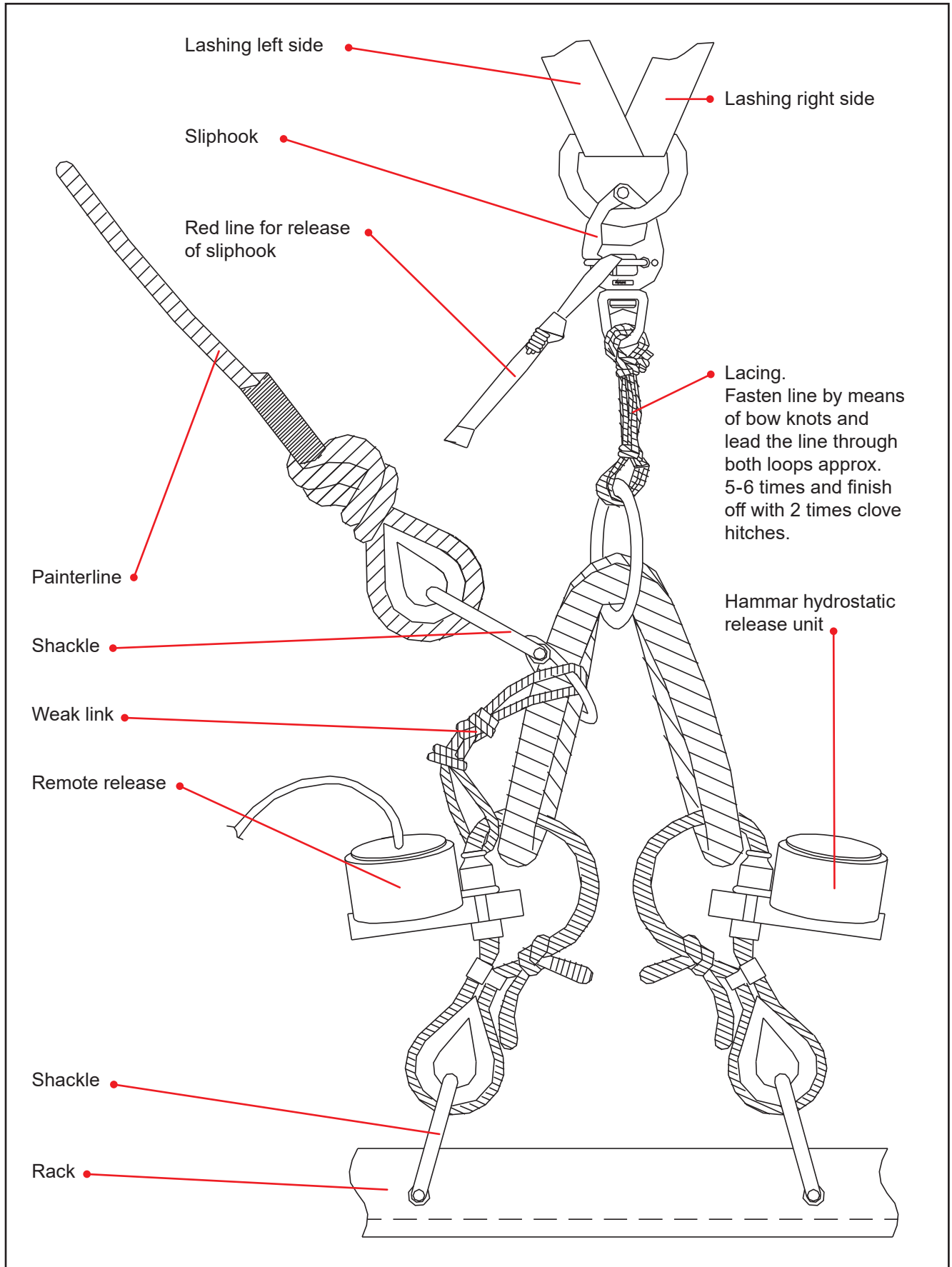

Mounting instruction for VIKING column rack

V-MI- 0194



Mounting of release unit type HAMMAR HC 0213 with remote release

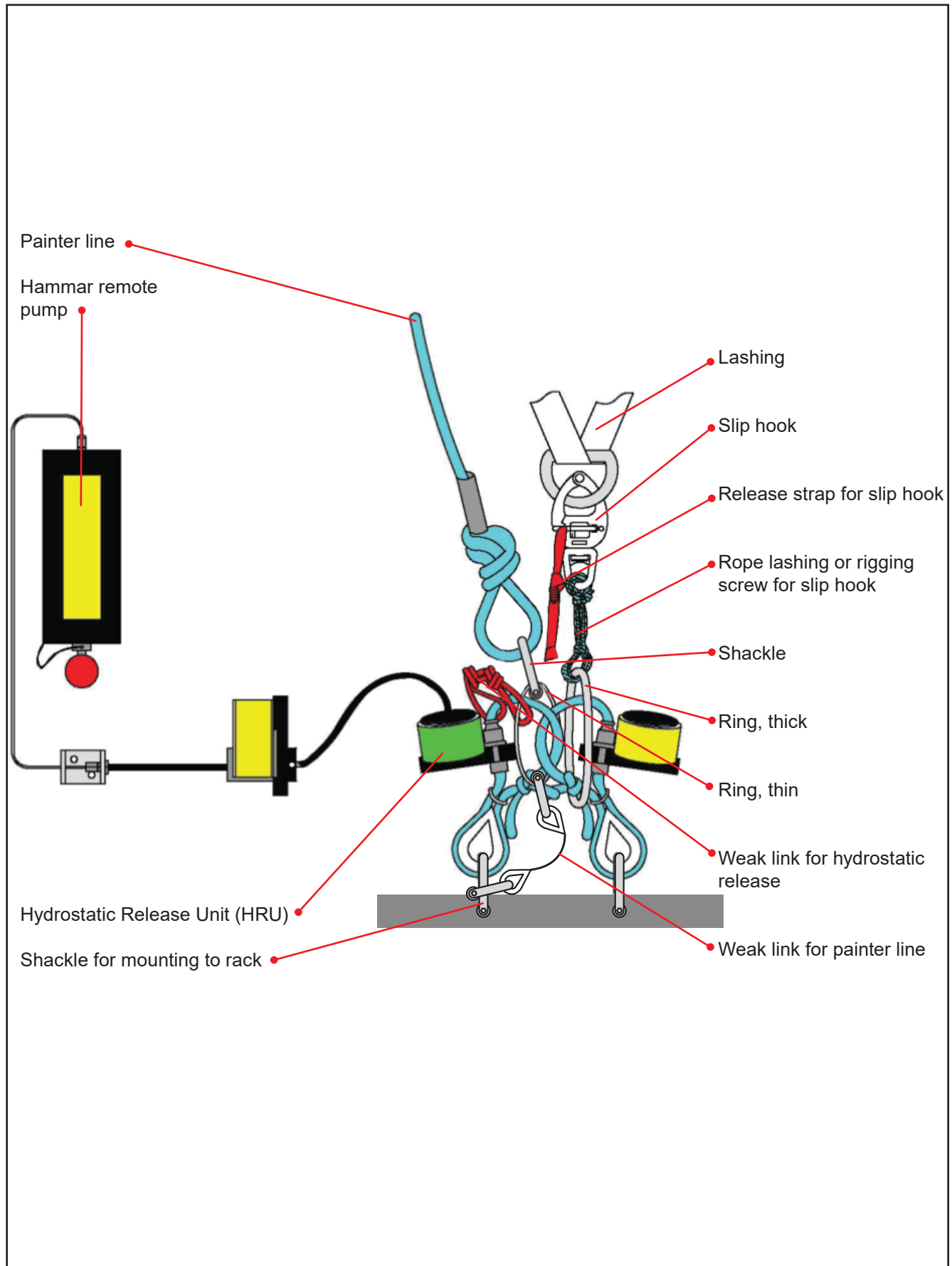

Mounting instruction for VIKING column rack

V-MI- 0194



Mounting of release unit type HAMMAR for 100 pers. liferafts without remote release

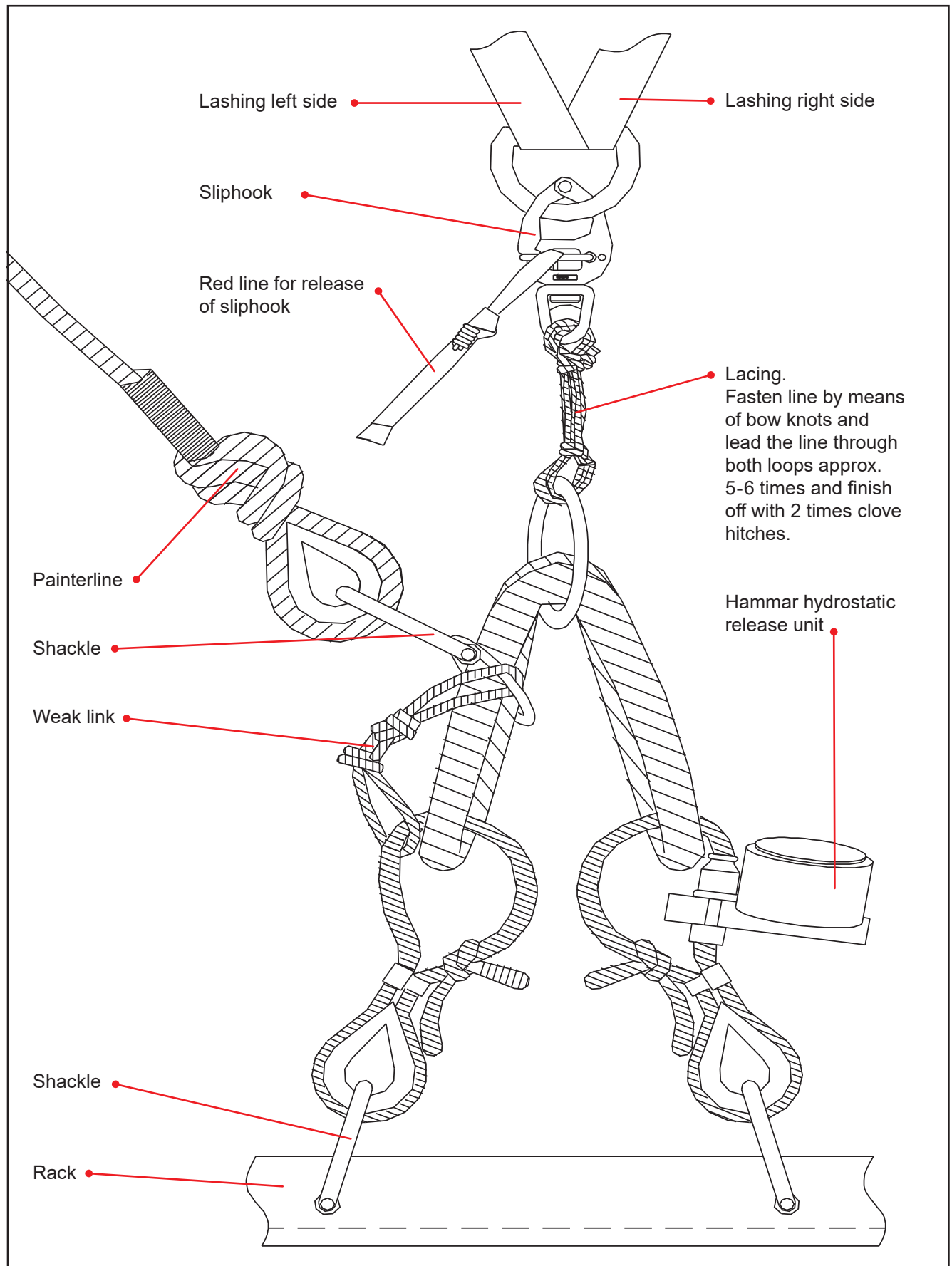

Maintenance of Hooks and Lashing

This instruction is to help to control and maintain lashings of liferafts, that are not part of the Marine Evacuation System.

Lashing

The lashing of liferafts should be tight. Over the years they can start to rot, therefore you might have to change these.

Lashings have an approximate lifetime of 10 years. Lashings produced from 2018 forward are marked with date of manufacture, making it easier to plan replacement.



Lashing

Hook

VIKING has two types of hooks, Pelican hooks and Slip hooks.

Both are made of corrosive resistant material, but on rare occasions corrosion may be found.

Both can be maintained by greasing with GREASE OMEGA 66, Material no.1012028 or Anti-corrosion wax based treatment with coating TT-290 material no.1065173. Long-time protection of steel parts. Apply the corrosion protection on the surface with a brush. Wipe off all excessive wax without removing the wax from moving parts.

Ensure to replace when corrosion is observed, or let it be fixed by the servicing station, when liferaft is in for service.

All spare parts can be purchased through the VIKING Servicing Network.



Pelican hook



Slip hook